



Project no. 218588

INTEGRITY

INTERMODAL GLOBAL DOOR-TO-DOOR CONTAINER SUPPLY CHAIN VISIBILITY

Instrument: Large Scale Integrating Project – CP-IP

Thematic Priority: Co-Modality – Encouraging Modal Shift and Decongesting Transport Corridors

Deliverable D0.3

Final Report

Due date of deliverable: 31/12/2011

Actual submission date: 31/12/2011

Start date of project: 01/06/2008

Duration: 42 Months

Organisation name of lead contractor for this deliverable:

ISL

Document ID code: 01-RD-D0.3-2011-final

REVISIONS/DOCUMENT HISTORY:

Index	Date	Authors	Reviewers	Subject
0	31/12/2011	NML (ISL)		Compilation and editing of contributions from the authors
1	6/1/2012	MvO (EUR)		review
2	10/2/2012	NML (ISL)		Amendments according to comments from the reviewers

CLASSIFICATION AND APPROVAL

Classification: Public (PU)

DEFINITION

PU = Public

PP = Restricted to other programme participants (including the Commission Services).

RE = Restricted to a group specified by the consortium (including the Commission Services).

CO = Confidential, only for members of the consortium (including the Commission Services).

Public after Review:

The document may be freely distributed after successful EC review, given the EC's permission. Publication is governed by the EC Grant Agreement and the INTEGRITY Consortium Agreement.

Confidential for the Duration of the Project:

As for 'Confidential', but only for the duration of the Project. After final Project Approval by the EC, status for reports classified 'Confidential for the Duration of the Project' are automatically down-graded to 'Public'.

Confidential:

The document is for use of the SCP7-GA-2008-218588 INTEGRITY Contractors within the INTEGRITY Consortium, and shall not be used or disclosed to third parties without the unanimous agreement within the INTEGRITY PMC and subsequent EC approval since document classification is part of the EC Grant Agreement.

Any executive summary specifically intended for publication may however be made known to the public by the author and/or the Coordinator.

Editor:

Name	Company	Date
Nils Meyer-Larsen	ISL	31-12-2011

Authors:

Name	Company	Date
Brian Atkinson	FDRC	31-12-2011
Jan van Dalen	EUR/RSM	31-12-2011
Marcus Engler	ISL	31-12-2011
Juha Hintsa	CBRA	31-12-2011
Lingzhe Liu	EUR/RSM	31-12-2011
Eric Lung	HIT	31-12-2011
Rainer Müller	ISL	31-12-2011
Michael Obsadny	ISL	31-12-2011
Marcel van Oosterhout	EUR/RSM	31-12-2011
Robin Pattinson	FDRC	31-12-2011
Johan Soema	EUR/RSM	31-12-2011
Luca Urciuoli	CBRA	31-12-2011
Albert Veenstra	EUR/RSM	31-12-2011
Xiao Wu	EUR/RSM	31-12-2011
Panagiotis Ypsilantis	EUR/RSM	31-12-2011
Rob Zuidwijk	EUR/RSM	31-12-2011

Reviewers:

Name	Company	Date
Gillian Castle	HMRC	17-01-2012
Frank Heijmann	DTCA	17-01-2012
Marcel van Oosterhout	EUR/RSM	06-01-2012
Luca Urciuoli	CBRA	09-01-2012
Terence Tsang	YICT	23-12-2011

APPROVAL:

All partners of the project consortium via a return email have approved the final version of this INTEGRITY Deliverable.

DISCLAIMER

Use of any knowledge, information or data contained in this document shall be at the user's sole risk. Neither the INTEGRITY Consortium nor any of its members, their officers, employees or agents accept shall be liable or responsible, in negligence or otherwise, for any loss, damage or expense whatever sustained by any person as a result of the use, in any manner or form, of any knowledge, information or data contained in this document, or due to any inaccuracy, omission or error therein contained.

The European Commission shall not in any way be liable or responsible for the use of any such knowledge, information or data, or of the consequences thereof.

Table of Contents

1	Executive Summary Suitable for Publication	11
2	Introduction	14
2.1	Background	14
2.1.1	Supply chain visibility	16
2.1.2	Global trade facilitation requirements	16
2.2	Objectives of INTEGRITY	17
2.3	The INTEGRITY concept	20
2.4	Expected Benefits	22
2.5	INTEGRITY Partners	26
3	Requirement Analysis	27
3.1	Background	27
3.2	Stakeholder analysis	28
3.3	Requirement formulation	29
3.4	Generic document and information exchange	29
3.5	Customs requirements	31
4	The SICIS system	34
4.1	SICIS architecture	34
4.2	Existing information exchange and SICIS	36
4.3	Container Journey	38
4.4	Container Query	39
4.5	Container Information	40
4.6	Container tracking	42
4.7	Consignment Level Information	42
4.7.1	Document Upload	42
4.7.2	Search and access to Consignment Information	42
4.8	Vessel Information	44
4.9	Container Security Devices	46
4.9.1	Savi Networks	46
4.9.2	LongSun	47
4.9.3	CIMC	48
4.9.4	CHINOS	48
5	The SICIS demonstration phase	49
5.1	General information	50
5.2	Tasks performed by users of the system	50
5.2.1	Start Container Journey by using a SAVI Container Security Device	50
5.2.2	Start Container Journey by manual data input	51
5.2.3	During a Container Voyage	51
5.2.3.1	Using a CSD	52
5.2.3.2	Using no CSD	52
5.2.4	Finalise a container at the point of destination	52
5.2.4.1	End Container Journey by manual data input	52
5.2.4.2	End Container Journey by removing CSD	53
5.2.5	CSD data	53
5.2.6	Container Scanning	53
5.2.7	AIS Data in SICIS	54

5.2.8	Consignment information	55
5.3	Events tracked in SICIS	56
5.4	Demonstration Results	58
5.4.1	Data availability in SICIS	58
5.4.1.1	Basic data sets by manual data input	59
5.4.1.2	Events including Hutchison Data Network (HDN)	59
5.4.1.3	Data gained by use of CSDs	59
5.4.2	Conclusion of CHINOS tests	61
5.5	Lessons learned during INTEGRITY demonstration	62
5.5.1	The fallback solution	62
5.5.2	Cell phone use	62
5.5.3	Data gained from one terminal provider only	63
5.5.4	Manual data input versus automatically gained data	63
5.5.5	Satellite vs. terrestrial AIS vessel tracking data	63
6	Modelling the SICIS benefits	64
6.1	Monitor and Control Loops	65
6.2	Quality of information: Visibility	68
6.3	Performance indicators	69
6.4	Identification and quantification of benefits	71
6.4.1	First level benefits	73
6.4.2	Second level benefits	73
6.4.3	Third level benefits	73
6.4.4	Derived benefits	75
6.4.5	Adverse effects of visibility	76
6.5	Results of the benefits analysis	76
6.5.1	Trade lane analysis	76
6.5.2	Potential trade lane benefits	77
7	INTEGRITY Business Evaluation Survey	78
7.1	Conceptual model	78
7.2	The survey design	79
7.3	The survey target group	79
7.4	Findings of the Evaluation	79
7.4.1	Response	79
7.4.2	Perception of SICIS	80
7.4.3	Organizational Readiness	84
7.4.4	External Pressure	85
7.4.5	User Satisfaction and Intention to Use	86
7.4.6	Expected Benefits	87
7.4.7	Individual Performance Impact	88
7.4.8	Expected Direct Impact on Organizational Performance	88
7.4.9	Expected Indirect Impact on Organizational Performance	89
7.4.10	SICIS modules	89
7.4.11	Business Model for SICIS	90
7.4.12	Provider of SICIS	91
7.5	Conclusions of the business evaluation	91
7.6	Limitations and Recommendations	92
8	The SICIS business model	93
8.1	Value Propositions	95

8.1.1	Benefits	95
8.1.2	Structuring the benefits	99
8.1.3	Benefits and the different devices	100
8.1.4	Offers	101
8.1.5	Revenue Streams	104
8.2	The Value propositions	104
8.3	Current positioning of SICIS	106
8.4	Business Models for SICIS	107
8.4.1	Business Model 1: Data	108
8.4.2	Business Model 2: Information	108
8.4.3	Business Model 3: Platform	109
8.4.4	Business Model 4: Consultancy	110
8.5	Charging structures for SICIS	110
9	Revenue generation and exploitation scenarios	111
9.1	Generic exploitation scenarios	111
9.2	Specific Exploitation scenarios	112
9.2.1	Scenario 1: Continuation of SICIS services after the project and extension in further research	112
9.2.2	Scenario 2: Providing SICIS as part of a port community service	112
9.2.3	Scenario 3: Developing SICIS into a container terminal pooling platform	114
9.3	Exploitation strategy	114
9.3.1	Information product development	114
9.3.2	Consultancy applications	116
9.3.3	Data pipeline	116
9.4	Customs use scenarios	117
9.4.1	Current situation (without ICS)	117
9.4.2	Current situation with ICS	118
9.4.3	Future situation	118
10	Vessel arrival prediction as a value added service	119
10.1	Introduction	119
10.2	The SCEM approach	119
10.3	Decision rules	120
10.4	Vessel Arrival Prediction	121
10.4.1	Demonstration Results	122
10.4.2	Gaps in the current system	124
10.5	Conclusion of the vessel arrival prediction	126
11	Clustering with the SmartCM project	127
11.1	Interoperability	127
11.2	Common Evaluation Criteria	128
11.3	Limitations and reflection	129
11.4	Joint Demonstration with SmartCM	129
11.4.1	Tradelane	130
11.4.2	CSD Performance	131
11.4.3	SICIS Conclusions	131

12	Consensus Building Activities	131
13	Conclusion	132
14	Acknowledgements	133

List of Figures

Fig. 1:	Importance of the top 10 management issues in the over-ocean supply chain	14
Fig. 2:	Top Pressures for Improving Supply Chain Visibility	15
Fig. 3:	Top 10 Enhancements for Global Visibility	18
Fig. 4:	Top 10 Enhancements for Domestic Visibility	18
Fig. 5:	Supply Chain Visibility focus	19
Fig. 6:	Origin of the main INTEGRITY door-to-door chains	21
Fig. 7:	Destinations of the main INTEGRITY door-to-door chains	21
Fig. 8:	Cargo Potential from China	22
Fig. 9:	Benefits of RFID Tracking	22
Fig. 10:	Increased value from visibility	23
Fig. 11:	Benefits to be achieved by smart technologies	24
Fig. 12:	Overview of the requirement analysis process	27
Fig. 13:	Features of basic, extended, and foreseen SICIS	35
Fig. 14:	Information flow relevant for SICIS	37
Fig. 15:	Information input and output in SICIS	38
Fig. 16:	Overview of monitored containers	39
Fig. 17:	Detail view of a container	40
Fig. 18:	Container movement list	40
Fig. 19:	Detailed milestone data of a container	41
Fig. 20:	Map view of a container's journey	42
Fig. 21:	Container enquiry screen	43
Fig. 22:	Container detail view	43

Fig. 23: Vessel list	45
Fig. 24: Vessel watch list	45
Fig. 25: Manual creation of vessel events	46
Fig. 26: Initialisation of a Savi Networks CSD	46
Fig. 27: Activation of a Savi Networks CSD	47
Fig. 28: LongSun CSD	47
Fig. 29: CIMC CSD	48
Fig. 30: CHINOS handheld with integrated container RFID tag and eSeal reader	49
Fig. 31: Activation of the CSD	51
Fig. 32: Container voyage including a container scan in YICT	54
Fig. 33: Complete container voyage including recognition of waypoints	55
Fig. 34: Different possibilities to insert Consignment reference numbers	55
Fig. 35: Manual start and end container journey	56
Fig. 36: Start and end container journey with mobile interface	56
Fig. 37: Manual start and end container journey using Hutchison ports	56
Fig. 38: Using a SAVI CSD only	57
Fig. 39: Using a SAVI CSD and Hutchison ports	57
Fig. 40: Using a SAVI CSD, Hutchison ports and AIS data	57
Fig. 41: Using country-based CSDs, Hutchison ports and AIS	58
Fig. 42: Reading of container RFID tag and eSeal data using the CHINOS handheld RFID reader	61
Fig. 43: Information flows	64
Fig. 44: Monitor and control loop	65
Fig. 45: System improvement and trade-offs between benefits	71
Fig. 46: Structure of the benefits analysis.	72
Fig. 47: Definition of slack time based on probability distribution and tolerance.	74
Fig. 48: decoupling points in the global supply chain.	77
Fig. 49: Business evaluation framework	78

Fig. 50: Evaluation of the SICIS system	80
Fig. 51: Evaluation of System Compatibility	81
Fig. 52: Evaluation of SICIS System Quality	82
Fig. 53: Evaluation of SICIS Information Quality	83
Fig. 54: Evaluation of Switching Costs	83
Fig. 55: Evaluation of Authorization	84
Fig. 56: Evaluation of Organization Readiness	85
Fig. 57: Evaluation of External Pressure	86
Fig. 58: Evaluation of User Satisfaction and Intention to Use	86
Fig. 59: Evaluation of Expected (Net) Benefits	87
Fig. 60: Evaluation of Individual Performance Impact	88
Fig. 61: Evaluation of Expected Direct Impact on Organizational Performance	88
Fig. 62: Evaluation of Expected Indirect Impact on Organizational Performance	89
Fig. 63: Evaluation of SICIS Modules	90
Fig. 64: Feedback on how to make use of the data	90
Fig. 65: Feedback on how to use the SICIS service	91
Fig. 66: Nine building blocks of a business model (Osterwalder & Pigneur (2009))	94
Fig. 67: The Business Model environment (Osterwalder & Pigneur (2003))	95
Fig. 68: Value of Tracking and Tracking information	101
Fig. 69: Offers and the Value of Tracking and Tracking information	103
Fig. 70: Current positioning of SICIS	107
Fig. 71: Alerting service in SICIS	109
Fig. 72: Generic exploitation scenarios of SICIS	111
Fig. 73: Hypothetical exploitation scenario for SICIS	113
Fig. 74: Business model canvas Ship Information Service	116
Fig. 75: Vessel schedule provided by Hyundai	122
Fig. 76: Example of an archived Vessel Arrival Prediction	123
Fig. 77: Example of actual arrival times	123

Fig. 78: Comparison for Hyundai Loyalty	124
Fig. 79: Data flows during joint demonstration	130

List of Tables

Tab. 1: The INTEGRITY Consortium	26
Tab. 2: Data element capture summary counts	32
Tab. 3: Data sources for the SICIS milestones	39
Tab. 4: Categories and dimensions of data quality (Strong et al. (1997)).	68
Tab. 5: Types of indicators and examples (Beamon (1999))	70
Tab. 6: Balance score card questions, goals, and performance indicators (Kaplan and Norton (1992)).	71
Tab. 7: Three levels of (potential) benefits	72
Tab. 8: Value propositions framework	99
Tab. 9: Devices and their benefits	100
Tab. 10: Offers	102
Tab. 11: Business models and charging options	110

1 Executive Summary Suitable for Publication

INTEGRITY is the acronym for the project "Intermodal Global Door-to-Door Container Supply Chain visibility", supported by the European Commission under the "Encouraging Modal Shift and Decongesting Transport Corridors" thematic area, Cooperation (Surface Transport) Programme of the 7th Framework Programme. The support is given under the vehicle of CP-IP (Large Scale Integrating Project), Grant Agreement No. 218588.

In the following, a brief overview of the project's results and achievements is given:

System

1. The Shared Intermodal Container Information System (SICIS) was developed, built, tested and is currently in operation. The system's main function is to integrate data from different sources along container supply chains, offering door-to-door tracking of containers. This level of coverage is fairly unique, and is not often available through common visibility systems. The main data groups in the systems are: chain partner identification (role, security compliance), container chain structure (via a template), container tracking and cargo details.
2. The SICIS system is technology independent, and a standard interface for container security devices has been built which was adopted and implemented by three container security device suppliers (Long Sun, CIMC and Savi Networks).
3. Interoperability with the SmartCM neutral layer has been established, and joint demonstration has been successfully performed.
4. The SICIS system was demonstrated with over 5400 containers being tracked in the system. System performance is very good, with uptime above 99% and response times that are limited. Data latency performance is also limited if the data is acquired from other systems. Data latency for manual data input can be high.

Users

5. During the project, the system was used by all INTEGRITY tradelane partners. Some have indicated that they would like the service to be continued after the project.
6. An extension of the user group has been achieved with one additional partner in the Netherlands, who aim to use SICIS as a platform to integrate data from sea-terminal-hinterland transport
7. The system is used to keep track of devices as they are brought into the European and Chinese territory as part of the registration of the devices for temporary import.
8. The system can be used by Customs to verify true consignee and consignor in specific tradelanes.
9. Finally, the system could be used as a document repository for Customs to look up additional documentation on high risk containers. This functionality was available, but not included in the demonstration.

Business model

10. Extensive business model scenarios have been developed that show that the system could be marketed in four different ways: as a data wholesaler, as an

information/visibility platform, as a basic software platform for third party information services, and as a consultancy tool. The project has developed activities to develop each of the possibilities described below.

- a. Data wholesaling could be achieved by integrating terminal operations data and selling it to large visibility platforms. This depends on the completeness of the data, and discussions with additional terminal operators are underway. Another discussion that is underway is the possibility of a connection with a Chinese Customs data system, which could be a source for cargo details. In this scenario, SICIS would act as the wholesaling channel for combined cargo and container tracking data.
 - b. The visibility platform option is currently being discussed with some partners, who use SICIS as a stepping stone towards a better visibility service for their specific business.
 - c. The basic platform option is explored through the development of the ship arrival prediction tools, which will be offered as an independent 'plug in' on the system, with its own business model. A serious application in this context is developed outside INTEGRITY (in the Dinalog project ULTIMATE, and the Dutch Pieken in the Delta project Nationaal Logistiek Informatie Platform), but is believed to lead to a marketable ship arrival/container release service in Rotterdam towards the end of 2012. This development is in cooperation with the Rotterdam port community system.
 - d. The use of SICIS as a consultancy tool has been developed by including SICIS in a number of follow-up projects.
11. Arrangements have been made to keep the system running after the termination of the project. While there is no clear business investment in the system yet, the options and commercialization scenarios listed above are too interesting to shut the system down at this stage.

Policy

12. In the course of the project, the vision on new ways of working for Customs have been developed substantially by Dutch and UK Customs.
13. Based on a field trip to China and Hong Kong in April 2010 and discussions afterwards in the Dutch Ministry of Finance and HMRC, an improved understanding in Customs has been generated on
 - a. The practical operations and consequences related to the EU ICS/ECS regulation for advanced notification to Customs,
 - b. The need for visibility in logistics chains and the reasons for the current bottlenecks,
 - c. The development of a vision on future data acquisition and supervision by Customs in international supply chains. This vision paper (the "Data Pipeline") is quite influential, and has and will be presented in many conferences and Customs meetings.
14. In the course of the project, a good understanding has been developed with Chinese Customs on the need for cooperation, and on the specific arrangements that need to be put in place for innovative projects using tracking technology. The license for temporary import of container security devices is a great achievement in this context.

Dissemination and impact

15. The INTEGRITY consortium was involved in co-organising ECITL2009 and ECITL2011 conferences and INTEGRITY's coordinator acted as local host of ECITL2010 conference.
16. The scientific contributions of INTEGRITY were presented at around 30 scientific and professional conferences in Belgium, Chile, China, Denmark, Germany, Greece, Italy, Malaysia, Netherlands, Norway, Portugal, South Korea, Sweden, Switzerland, Turkey, and the United States of America.
17. During the course of the project, cooperation with projects CHINOS, e-freight, Euridice, Freightwise, Logistics4Life, Smartfreight and others were established. This has also led to the INTEGRITY contribution to the Common Framework Paper and the L4Life Roadmap jointly produced by current EC logistics information systems projects.

2 Introduction

2.1 Background

Current state-of-the-art logistics door-to-door chains still show a lack of information flows preventing the provision of high efficient and reliable services. A.T. Kearney surveyed some of the biggest importers and exporters of the US on requirements in supply chains and in cooperation with the International Cargo Security Council (ICSC)¹. Their key concerns in the over-ocean supply chain were prioritised and can be found in the following graph:

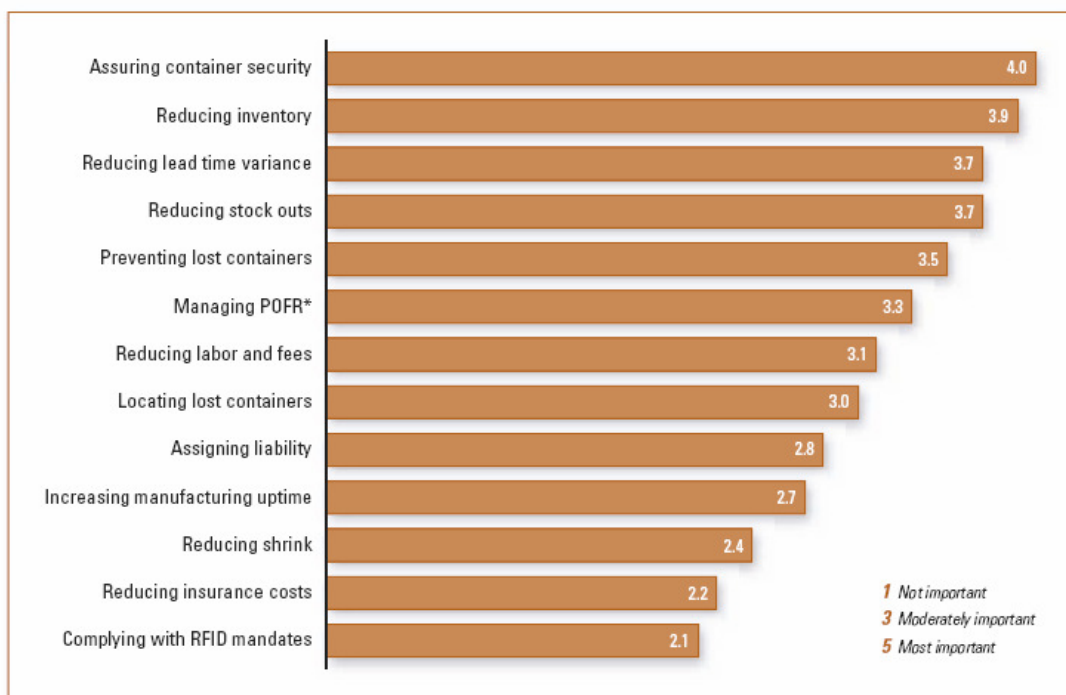

*POFR stands for perfect order fill rate, a measure of order accuracy, time/ness, quality and completeness.
Source: A.T. Kearney

Fig. 1: Importance of the top 10 management issues in the over-ocean supply chain

The Aberdeen Group published in its “Supply Chain Visibility Roadmap”² the following items being of relevance for INTEGRITY:

- “Supply chain executives identify improving visibility as their number one priority. They overwhelmingly desire better transparency to orders, inventory, and shipments across their extended supply chain.”³
- “Top performers avoid using visibility technologies to create a turbocharged tracking system; rather, they use visibility systems to drive sustainable

¹ A.T. Kearney: Smart boxes - RFID Can Improve Efficiency, Visibility and Security in the Global Supply Chain, Chicago 2005

² Aberdeen Group: The Supply Chain Visibility Roadmap – Moving from Vision to True Business Value, Boston November 2006

³ *ibid.*, p. i.

improvements in lead times, delivery reliability, and inventory reductions. Many of them are now focusing on using visibility information to protect gross margin and capture more market share.”⁴

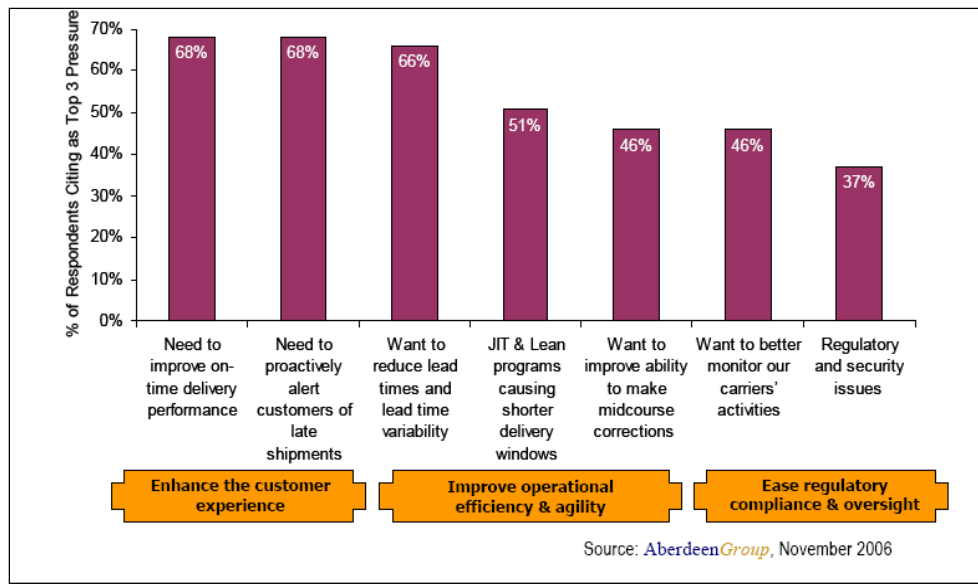

Fig. 2: Top Pressures for Improving Supply Chain Visibility

The White Paper from the industry funded supply chain security and efficiency initiative “Smart & Secure Trade lanes”⁵ listed the following problems and challenges:

- supply chain data is missing or inaccurate, untimely or incomplete making it invaluable for decision making
- arrival notices appear days after the arrival
- check of mechanical seals for tampering are performed only partly
- containers deviate from their assigned routing.

In respect of security we notice several measures and initiatives to enhance the security, such as the ISPS Code for port and maritime operators, but a real worldwide approach, notwithstanding some attempts as the US program OSC Operation Safe Commerce and SST Smart and Secure Trade Lanes, covering the entire supply chain from origin to destination, is still missing.

The World Customs Organisation (WCO) recommends to push the cargo control to the exporting country rather than performing these checks at the late stage of arriving in the import country as performed today. Optimal clearance procedures will start with the container stuffing, eSeal or Container Security Device, use of Authorised Economic Operator (AEO) scheme along the chain and harmonised procedures between the various Customs Authorities. Every level of implementation seems possible and beneficial.

In the EU, the Authorised Economic Operator (AEO) approach from DG TAXUD is moving on while the Draft Supply Chain Security Directive (Secure Operator concept) will be re-evaluated by DG TREN in the light of this recently revised Customs Code introducing the AEO concept.

⁴ ibid.

⁵ Smart & Secure Tradelanes: Phase One Review – Network Visibility: Leveraging Security and Efficiency in Today’s Global Supply Chains, November 2003

The intention of the European Commission (DG TREN) to regulate this issue in the European Union with its Draft Supply Chain Security Directive (Secure Operator concept) will be re-evaluated in the light of the recently revised Customs Code introducing the concept of the AEO concept.

Due to the unpredictability and unreliability, actual procedures lead to certain bottlenecks:

- too many goods have to be held in safety stocks
- too many goods are locked in security processes

leading to avoidable economic drawbacks being increased costs and reduced quality which can be offered and guaranteed to the clients.

Customs Authorities are facing challenges for their daily work caused by increasing number of import containers to be screened and scanned, low quality of information with regard to data quality, completeness, timeliness, and data integrity for the containers to be processed.

Customs procedures vary even within Europe: e.g. some countries put all import containers on hold unless they are explicitly released, some others do it the other way round: all containers are released unless they are set on hold.

On the other hand, transport and terminal operators as well as authorities are keen getting organised their whole transport chains in the most secure and efficient way.

Procedures and processes applied to other means of transportation will also be taken into account and analysed for usability in container supply chain processes, e.g. airfreight, air waybill numbers and related processes.

2.1.1 Supply chain visibility

Companies demand better transparency of orders status, inventory, and shipments across their extended supply chain. In the supply chain, visibility is a precondition to adequately manage events. There are three main obstacles to achieve visibility:

- Organisational: it is difficult to address the responsibility for visibility since it transcends different organisational functions and regional boundaries that all benefit from improved visibility.
- Technology: Visibility systems have to gather information from multiple internal and external systems; that requires many interfaces to other systems. However, web services, B2B hubs, and transportation carrier portals are now making interfaces more manageable.
- Managing visibility information: how to drive strategic business improvement from visibility information. Additional technology and organizational capabilities are needed to achieve this. Companies need a system which can monitor the events in the entire supply chain and that provides reports to all stakeholders involved.

Another issue in achieving supply chain visibility is related to the strategic importance of information. A major dilemma for companies is to decide to share information or not to.

2.1.2 Global trade facilitation requirements

Facilitating global trade is a crucial element of the mission of Customs agencies. One of the objectives to achieve this is by eliminating duplication and delays in international supply chains such as multiple reporting requirements and inspections. This process of simplification, however, should also adequately reflect the requirements of increased security. This has resulted in a series of measures:

- the proposed Community Customs code security amendments (regulation 648/2005)
- require traders to provide Customs authorities with information on goods prior to import to or export from the European Union (see Pre Arrival / Pre Departure Declarations);
- provide reliable traders with trade facilitation measures (see Authorized Economic Operator AEO);
- introduce a mechanism for setting uniform Community risk-selection criteria for controls, supported by computerised systems
- the Customs security program to harmonise control standards and facilitate trade by the AEO programme.
- the AEO program. AEO certified traders can obtain simplified Customs procedures.

The benefits of these programmes are often covered under the all encompassing term of 'creating green lanes'. This means that import cargo, upon arrival, is already viewed, verified, and found secure before entry, and can pass across the border unhindered by Customs, or other inspection agencies. In many cases, such green lanes already exist, or are being developed, by removing bottlenecks in information exchange with Customs, and improving information exchange along the chain, both between business involved, and between Customs agencies in different countries.

The main challenges for simultaneously realising increased security as well as trade facilitation are:

- Mutual recognition of green lanes and trusted partners
- Harmonised risk management and assessment approaches
- Acceptance and trust in AEO benefits by industry

2.2 Objectives of INTEGRITY

The INTEGRITY project covers this lack of information described above by creating supply chain visibility (SCV) as a basis for securing intermodal container chains ("security tracing") on a door-to-door⁶ basis by evaluating information from various types of sensors and other information sources, partially (pre-)processed by intelligent algorithms. At the same time using a harmonised set of technologies logistics costs for the chains shall be minimised.

INTEGRITY puts European Commission policy objectives into force, e.g. from DG TAXUD (Customs), DG TREN (transport & logistics), DG Enterprise (security) by designing a neutral system approach that facilitates transport, improves its capacity and enhances the security. This objective are put into measurable performance indicators for the parties involved.

⁶ Door-to-door means from the stuffing and sealing of the container until the stripping and unsealing. Issues on consignment level are tackled only secondarily.

INTEGRITY takes into account the findings of the Aberdeen Group on the top topics to be implemented for Supply Chain Visibility⁷:

Top 10 Enhancements Planned in Next 2 Years	% Respondents Planning to Enhance
1. Expand number of trading partners providing status information	54%
2. Incorporate additional status events	50%
3. Track actual total landed cost as shipment/order progresses	45%
4. Incorporate resolution advice or workflow (e.g., expedite advice)	45%
5. Add financial settlement or financing triggers	45%
6. Add warning alerts if actual events deviate from plan	44%
7. Add RFID-enabled visibility	43%
8. Add escalation policies to help manage alerts	43%
9. Performance trending and root cause analysis	42%
10. Add visibility into mobile assets (e.g., containers, equipment)	41%

Source: AberdeenGroup, November 2006

Fig. 3: Top 10 Enhancements for Global Visibility

Enhancement	Have today	Plan to add in next 2 years	Interested but no formal plan	Total Interest Level
1. Warning alerts if events deviate from plan	33%	19%	43%	95%
2. View current at-rest and in-transit inventory	29%	14%	52%	95%
3. Visibility down to an order-line level	32%	18%	41%	91%
4. Escalation policies to help manage alerts	14%	19%	57%	90%
5. ETA updates based on actual events	36%	23%	27%	86%
6. Role-based views for other departments	19%	5%	57%	81%
7. Visibility into mobile assets	14%	19%	48%	81%
8. Time-phased visibility of future inventory positions	0%	24%	57%	81%
9. RFID-enabled visibility	5%	24%	48%	77%
10. Resolution advice or workflow	5%	24%	48%	76%

Source: AberdeenGroup, November 2006

Fig. 4: Top 10 Enhancements for Domestic Visibility

SCV will lead to a better reliability and predictability of transport chain performance by having the basic parties related to logistics (Cargo owners/3PLs, transport operators) and security (Customs authorities) issues “on board”.

⁷ Aberdeen Group: The Supply Chain Visibility Roadmap – Moving from Vision to True Business Value, Boston November 2006, p. 7f.

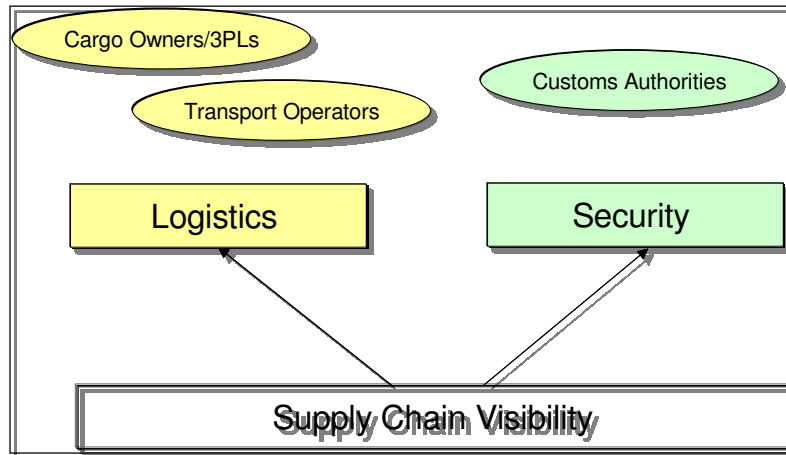

Fig. 5: Supply Chain Visibility focus

Organisational and technical measures will enhance the integrity and security and support the supply chain as a whole. They include:

- working with trusted parties (AEOs, authorized economic operators⁸)
- auto-ID possibilities for containers (OCR, RFID)
- X-ray inspection or container imaging (content) facilities
- radiation portals to identify nuclear materials
- e-seals or smart container security devices using multi-sensor networks monitoring the door condition, light, temperature, humidity, radiation, chemicals, etc. (especially in this area shipping companies can offer a variety of services according to the needs of their clients)
- mobile communication systems and platforms (e.g. short range communication, terrestrial and satellite based communication)
- satellite tracking of vessels and other vehicles (e.g. GNSS/Galileo in combination with global communication network for tracking vehicles, railway cars, barges etc. Vessels above 300 tons will be tracked via satellite based AIS. The U.S. Coast Guard has passed first contract to demonstrate this technology)
- databases with tracing and event information and intelligent algorithms to detect possible risks
- EDI or web services to perform validity and integrity checks with external databases (e.g. of transport operators to check if incoming containers are really expected, i.e. have been announced or booked by shipping lines or freight forwarders directly or via Port Community Systems; if eSeals detected correspond to seal numbers announced)

⁸ Documents from the World Customs Organisation and the European Commission can be found at http://www.wcoomd.org/ie/En/Topics_Issues/FacilitationCustomsProcedures/AEO%20Guidelines.pdf; TAXUD/C4 (2005) 1432, The Authorized Economic Operator, http://ec.europa.eu/taxation_Customs/resources/documents/Customs/policy_issues/Customs_security/AEO_strategic_paper_en.pdf

These measures can enhance the security of the chain and support the supply chain. Logistics benefits derived are higher transparency and predictability leading to economic benefits with regard to costs and quality of services thus enabling benefits for the whole door-to-door container chain.

Apart from technologies, the business processes (e.g. for monitoring the logistics chain, for gaining permissions from authorities, for speeding up checking at the changes of responsibilities in the chain) were analysed and adapted for exploiting the technology potentials in an optimal way. That is why the participation of Customs Agencies was essential.

The “TRUST BUT VERIFY” strategy expresses e.g. the combination of using trusted parties (AEOs) and scanning equipment for immediate control.

SCV supports decision making for logistics and security issues. The full control of data protection and data integrity is respected in the systems design and implementation. It has to be guaranteed that data access is only possible for eligible parties, only for fixed purposes and only after prior agreements.

Certain quality standards (to be defined as validation criteria) have to be met, e.g. dwell time on terminals must become less than 3.5 days on average.

Customs Authorities are provided with reliable, timely, partly pre-screened, evaluated streamlined input for their daily work on screening and scanning of containers. Customs Authorities agree on a common set of data facilitating pre-arrival clearance and release before the cargo arrives, this speeds up the whole process and – even more important - leads to an improved reliability and predictability of the whole chain.

The neutral scientific partners in the project assessed and measured the impacts of INTEGRITY, compared them with values of recent studies, guarded the accessibility and neutrality of the system, as well as secured the acceptability of the concept regarding all stakeholders and target groups. Due to high priority on the neutrality of the solution INTEGRITY is open for participation of other parties or consortia.

2.3 The INTEGRITY concept

The challenge for INTEGRITY is to integrate a lot of different aspects in a very complex environment into a homogeneous, holistic, neutral, reliable, robust and widely accepted concept. INTEGRITY integrates

- Technologies and procedures
- Business stakeholders and Customs Authorities
- Logistics and security issues
- All transport modes
- Small and medium sized enterprises (SMEs) and “big players”

INTEGRITY is an integration project on technology and processes with a strong focus on data integrity. Although a lot of building blocks are existing, most of the above mentioned technologies have been run through technical feasibility tests without tackling the integration into a common concept on the level of business processes, legal and administrative changes and possible incentives when using them in a consistent and reliable manner.

The combination of existing technologies together with new business processes, legal and administrative agreements between the “administration world” and the “logistics world” creates a win-win situation for both target groups.

The main focus is on door-to-door supply chains from China to Europe covering all modes of transport excluding air transport. The demonstration scenarios will follow the supply chains of the cargo owners involved in the project.

They start at shippers' premises or in consolidation centres in China where the containers are stuffed and sealed. Next step is truck transport to the terminal in Yantian in the Shenzhen area.

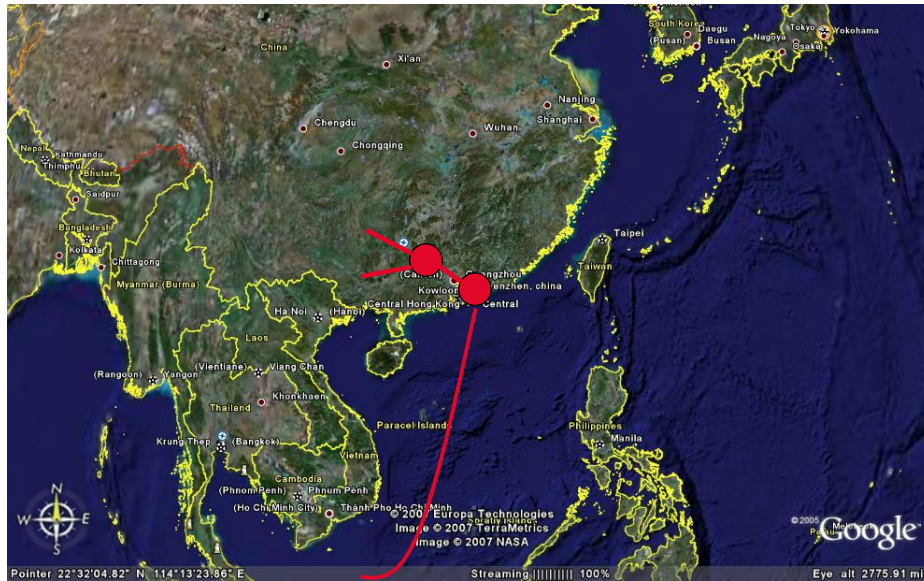

Fig. 6: Origin of the main INTEGRITY door-to-door chains

The ocean transport leg connects Yantian with Rotterdam and Felixstowe. On carriage from Rotterdam goes via all modes (rail, barge, road) to the trimodal inland terminals in Venlo or Duisburg in Germany and further on to the final customers. In the UK train and road services are applied.

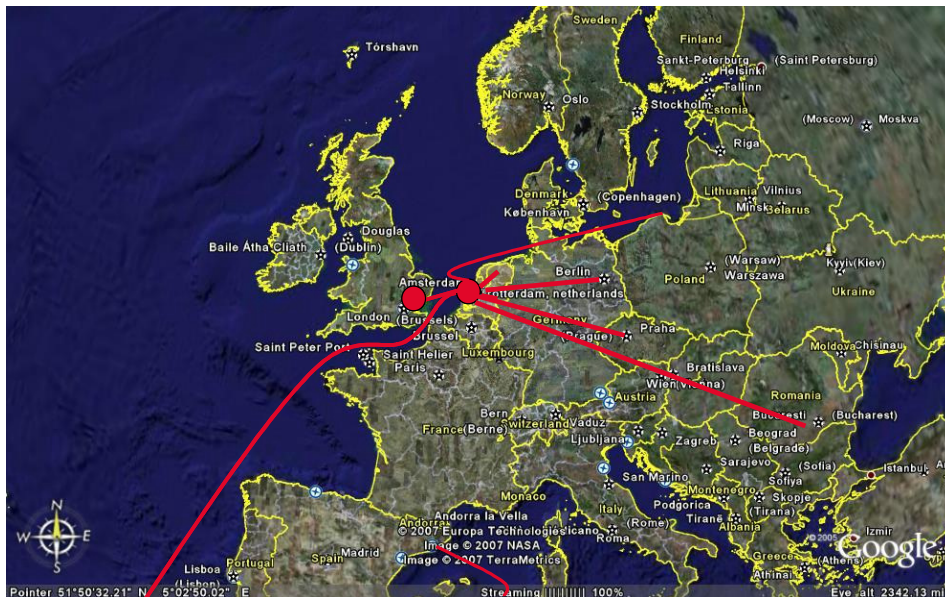

Fig. 7: Destinations of the main INTEGRITY door-to-door chains

End points of the chains (“exit doors” of the door-to-door chains) lie in Western Europe, Southern Europe and Eastern Europe.

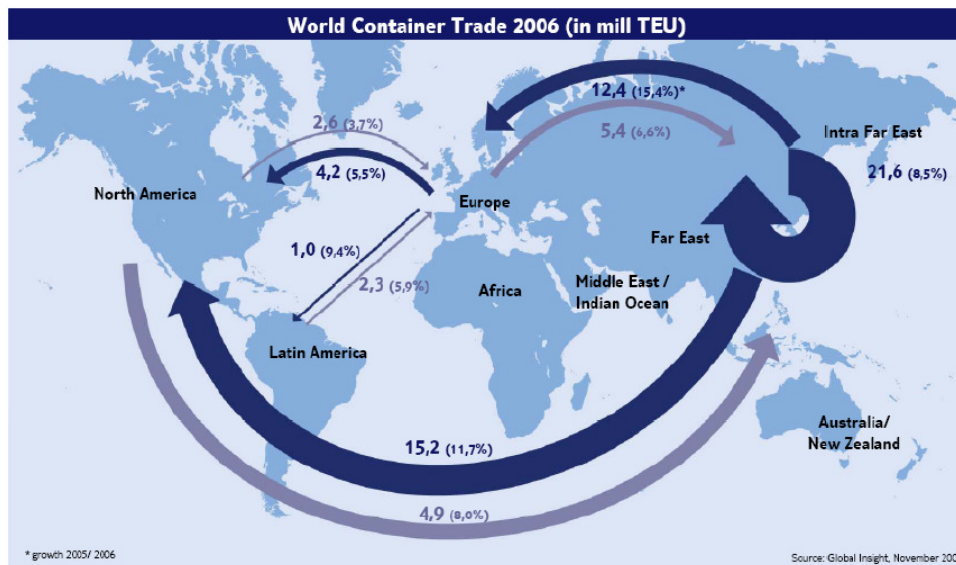

Fig. 8: Cargo Potential from China

2.4 Expected Benefits

The main goal and the main benefits of the INTEGRITY project are obvious: to make door-to-door chains more secure and smooth. Both main users (Customs, shippers) will be satisfied in one integrated approach.

Several recent investigations show that the enhancement of supply chain visibility provides economic benefits for all participants in the chain. The following references and figures clearly show this potential and will serve as basis for the validation criteria to be used in INTEGRITY.

A.T.Kearney investigated that for RFID application along the chain tremendous cost reductions can be achieved (up to 1,150 USD per transport)⁹:

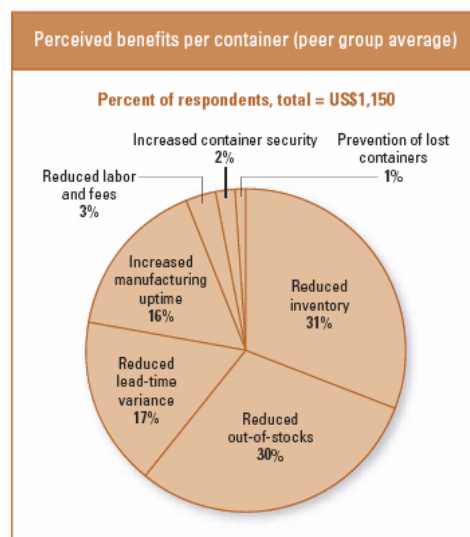

Source: A.T. Kearney

Fig. 9: Benefits of RFID Tracking

⁹ A.T.Kearney: Smart boxes - RFID Can Improve Efficiency, Visibility and Security in the Global Supply Chain, Chicago 2005, p. 9

The Aberdeen Group reasoned that according to the background and the related problems in supply chain visibility the following performance benefits can be achieved:

- “Inventory reductions: Companies that are Best in Class in inventory management are 2.4 times as likely to use a supply chain visibility system. These top performers have customer service levels of at least 96% and have reduced inventory levels since 2004, often by 20-30%
- Cycle times: Companies using a visibility system are three times as likely to have faster order to delivery times as those companies that have no plans to adopt such a solution.
- On-Time Deliveries: Companies that track more than 80% of their domestic shipments are twice as likely as their peers to have an on-time delivery rate of 95% or higher.”¹⁰
- Management by exception delivers effective shipment tracking, Supply Chain disruption management and Supply chain improvement as shown in Fig. 10¹¹

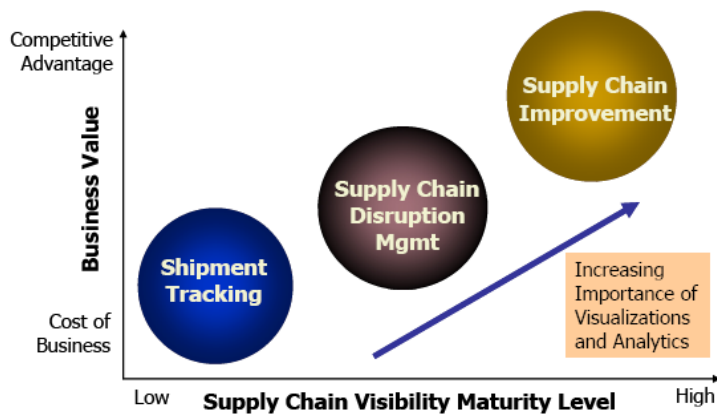

Source: AberdeenGroup, November 2006

Fig. 10: Increased value from visibility

A further summary of tangible benefits to be achieved by enhanced visibility shows¹²:

“Working Capital Benefits

- Reduced safety stocks and inventory investment
- Ability to use in-transit inventory as “available inventory” for order allocation decisions and inventory calculations
- Better fleet and mobile asset utilization

Customer Service Benefits

- Faster order fulfillment (and cash-to-cash cycle) times from eliminating bottlenecks and operating off of “true lead times”
- Fewer late deliveries, resulting in decreased chargebacks and other customer invoice deductions and penalties, as well as fewer stock outs and lost sales

¹⁰ Aberdeen Group: The Supply Chain Visibility Roadmap – Moving from Vision to True Business Value, Boston November 2006,p.4

¹¹ Aberdeen Group: The Supply Chain Visibility Roadmap – Moving from Vision to True Business Value, Boston November 2006, p.11

¹² Aberdeen Group: The Supply Chain Visibility Roadmap – Moving from Vision to True Business Value, Boston November 2006, p. 21

- Enhanced customer service via proactive issue notification and more accurate ETAs

Productivity Benefits

- Better workload balancing and productivity at manufacturing and distribution sites
- Enhanced expediting decisions and better transportation planning and scheduling (resulting in lower freight costs).”

The White Paper from the industry funded supply chain security and efficiency initiative “Smart & Secure Tradelanes”¹³ came to the following conclusions:

- “Real-time visibility into the status and location of shipments increases efficiency in the supply chain, which leads to substantial economic benefits for all participants.
- Information on the execution of the supply chain must be transparent – the physical chain of custody must be tightly linked with a virtual chain of information, and that information must be available to authorized participants on a strict need-to-know basis.”¹⁴

SST evaluations came to the conclusion that “a single end-to-end move of a typical container nets \$378-462 of potential value to the shipper”¹⁵ assuming an average cargo value of \$70,000. Some details are shown in the following figure.

Area of Potential Benefit	Potential Benefit Percentage of	Potential Per Container Benefit
Reduction in Safety Stock	.25-.30%	\$173-211
Reduction in Pipeline Inventory	.13-.16%	\$91-111
Reduction of Service Charges	.08-.10%	\$56-68
Administrative Labor	.04-.05%	\$31-38
Reduction of Pilferage, Inspections, Loss	.04-.05%	\$28-34
Total	.54-.66%	\$378-462

Fig. 11: Benefits to be achieved by smart technologies¹⁶

The Manufacturing Institute investigated benefits derived from innovators in supply chain security¹⁷:

¹³ Smart & Secure Tradelanes: Phase One Review – Network Visibility: Leveraging Security and Efficiency in Today’s Global Supply Chains, November 2003

¹⁴ ibid.

¹⁵ ibid., p.5

¹⁶ ibid., p.5

¹⁷ Peleg-Gillai, B. ; Bhat, G. ; Sept, L. (Manufacturing Institute) : Innovators in Supply Chain Security: Better Security Drives Business Value, Stanford 2006

- Improved product security (e.g., 38 percent reduction in theft/loss/pilferage, 37 percent reduction in tampering);
- Improved inventory management (e.g., 14 percent reduction in excess inventory, 12 percent increase in reported on-time delivery);
- Improved supply chain visibility (e.g., 50 percent increase in access to supply chain data, 30 percent increase in timeliness of shipping information);
- Improved product handling (e.g., 43 percent increase in automated handling of goods);
- Process improvements (e.g., 30 percent reduction in process deviations);
- More efficient Customs clearance process (e.g., 49 percent reduction in cargo delays, 48 percent reduction in cargo inspections/examinations);
- Speed improvements (e.g., 29 percent reduction in transit time, 28 percent reduction in delivery time window);
- Resilience (e.g., close to 30 percent reduction in problem identification time, response time to problems, and in problem resolution time); and
- Higher customer satisfaction (e.g., 26 percent reduction in customer attrition and 20 percent increase in number of new customers).

These examples show that the general objectives of INTEGRITY:

- Enhanced predictability and reliability of door-to-door container chains
- Reduction of uncertainty in these chains
- Enhancing the speed of administrative and operational performance (it should be noted that speed of performance and predictability are two different items though linked together; for the overall performance of the door-to-door chain predictability is often ranked higher than speed of operation)
- address the lack of critical supply chain visibility; uncoordinated multi-tier supply chain processes and longer lead times and lead time visibility

together with specific analyses on the benefits for all players in the chain as well as the comparison with the related costs for such a service will be included for:

- Customs organisations
- Exporters and importers
- Logistic chain and transport managers
- Port operators, ocean and inland
- Inland transport operators

can be investigated in validation scenarios using these criteria comparing expected procedures with existing ones; e.g. the use of eSeals will be compared with using standard high security seals.

Additional scanning must not create additional bottlenecks; therefore high resolution drive-through scanning equipment meeting all necessary International and local safety standards will be required. Customs will be fed with the automatic and pre-checked information (or can pull this information from SICIS) in order to perform the necessary checks within their system.

Concepts being actually discussed on an international and European basis (AEO concept, 24-hour manifest rule, etc.), were tested and validated in INTEGRITY.

The experience of the INTEGRITY project can be used for transition to 3rd countries meeting capacity building objectives. INTEGRITY and the SICIS system as neutral platform adding value to data will help satisfying the obvious need for supply chain visibility and exploiting all potentials benefits in supply chain optimisation.

2.5 INTEGRITY Partners

The INTEGRITY project is carried out by the following group of organisations, institutes and companies:

CONSORTIUM OVERVIEW			
Nr	Organisation Name	Country	Organisation Name (Abbreviated)
1	Institute of Shipping Economics and Logistics	DE	ISL
2	RSM Erasmus University, Erasmus University Rotterdam	NL	EUR
3	Cross-border Research Association	CH	CBRA
4	ECT Delta Terminal B.V.	NL	ECT
5	Felixstowe Dock & Railway Company, Port of Felixstowe	UK	FDRC
6	Yantian International Container Terminals	CHN	YICT
7	DeCeTe Duisburg GmbH	DE	DeCeTe
8	Xerox Manufacturing Nederland B.V.	NL	XEROX
9	Seacon Logistics	NL	SEACON
10	DHL Global Forwarding N.V.	BE	DHL
11	BAP Group Ltd	UK	BAP
12	A.S. Watson (Health & Beauty Continental Europe) BV	NL	ASWatson
13	HM Revenue & Customs	UK	HMRC
14	Dutch Tax Customs Authority	NL	DTCA
15	OHB Teledata	DE	OHB
16	ECT Venlo B.V.	NL	TCT

Tab. 1: The INTEGRITY Consortium

3 Requirement Analysis

This chapter describes the outcome of the user requirement analysis for the Shared Intermodal Container Information System (SICIS).

3.1 Background

In general, the development of a complex system (could be both a technical system, and a software system) consists of several standard processes:

- Agreement: agree on what needs to be built → formulate needs, problem definition, feasibility study
- Project: project plan, project execution, control
- Development: analyse mission, formulate functional requirements, define performance, systems model, building
- Evaluation: verify , validate, maintain

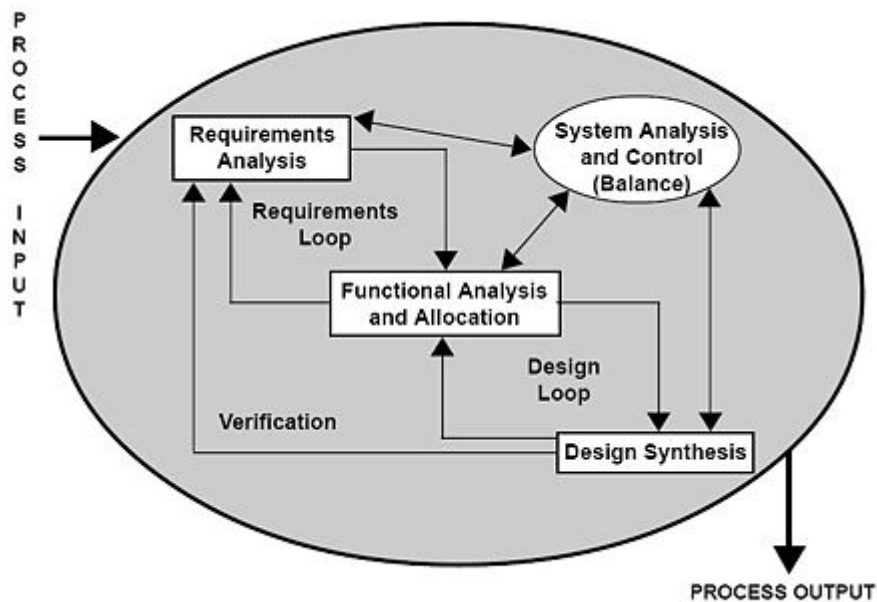

Fig. 12: Overview of the requirement analysis process

The first step in such a systems engineering project is requirement engineering. This consists of requirement eliciting, analysis and recording. In other words, as a first step, requirements have to be extracted from stakeholders, analysed, and then reported for future reference. The second step then is to translate these 'customer oriented' requirements into functional requirements for the way the system needs to function (so-called functional requirements).

In INTEGRITY, we are following the steps in this process. First, we have performed a supply chain analysis of the tradelanes in our project. This analysis has resulted in a good insight in the stakeholders for our SICIS system. Second, we have done user requirement interviews based on an open answer question list. This interview round can be regarded as the requirement elicitation process. We have then put all the questionnaires together, and extracted common user requirements that satisfy as many stakeholders as possible. This is the requirement analysis process. We are reporting the findings in this deliverable,

and in several workshops with stakeholders. Part of the reporting is done in the form of standardised system behaviour descriptions called use cases. Finally, we also use the workshops to exchange ideas, clarify issues, and build acceptance of the particular user requirements. This is the consensus building process.

Functional requirements are a translation of the pure user oriented requirements into generic requirements for the functionalities of the system. These functional requirements are still formulated in a rather general way, such as: the system should allow registration of company before they can enter or access information in SICIS.

As part of the functional requirements, the present report concentrates on the functional requirements related to data management: how does the data get entered into the system, what does the system do with the data (storage, analysis, verification), and how is the resulting information reported to the users?

An outcome of the process of user and functional requirements is the identification of so-called non-functional requirements. These are functionalities the system must have in order to perform its functions, but the user will not notice them. Examples are statements on the performance of the system, the speed of reacting to user queries and so on.

The objective of the user requirement analysis is to determine what the users expect from a system such as SICIS. This can be done in many different ways. In INTEGRITY, we have chosen for a combination of templates and questionnaires, together with consensus building workshops.

3.2 Stakeholder analysis

Stakeholder analysis from a single company perspective can be complicated: there are many ways to map out stakeholders, there are levels of stakeholders (key, first level, second level), there are different dimensions to identify stakeholders, and so on. In a networked context, such as a supply chain, where an activity stretches out across a chain of companies, stakeholder analysis can be even more elaborate and complex.

Another complicating factor is that the purpose of the INTEGRITY project is to contribute to solutions in the field of security. As soon as security of business activities, living environment or society is involved, the list of stakeholders grows exponentially, because potentially everything and everyone is affected.

We have chosen to keep the stakeholder analysis limited to the problem at hand: we need to develop an IT platform that will facilitate information exchange in the supply chains. We therefore concentrate, for the moment, on searching for stakeholders related to the supply chains that are of interest to us in the current project. These supply chains form tradelanes from China to Europe (via Rotterdam and UK).

At this point we can draw a number of conclusions from the supply chain scan that are relevant for the development of the SICIS system.

1. The main stakeholders are the shippers, freight forwarders, transport operators in pre- and on-carriage, terminals, shipping lines, warehouse operators, Customs and the ultimate users. The user requirement analysis will lead to the identification of a few more stakeholders.
2. The inclusion of empty depots as stakeholders in this stage does not seem necessary.
3. The current level of security measures is quite extensive, both due to compulsory regulation, and due to high level company or supply chain standards. However, on the Chinese side, there is a gap in knowledge on security standards.

3.3 Requirement formulation

From the user requirement analysis we can formulate the following requirements:

1. All tradelane partners desire to have good real time data on important operational milestones. Currently, most of them have systems in which these milestones are reported, but the data on which they are based is often unreliable, or the gathering of the data requires a lot of effort.
2. With some exceptions, tracking should take place at the purchase order number (alternatively: SKU, box, item level). Container tracking information is useless if it is not translated to purchase orders. Some partners would like to receive container tracking information in the future, mainly for the purpose of performance measurement of the shipping lines.
3. Exception reporting can take place in two ways: positive (alerts that milestones have been met) and negative (alerts that milestones have failed). Both are mentioned.
4. Most of the partners require the data to be fed into an existing system.
5. KPIs: the statements on KPIs are not clear. Most of the partners do not have any container based KPIs. KPIs in use are customer oriented, and focus on purchase order, item, box or consignment. As such, the user requirement analysis did not give much guidance for the selection of KPIs. The score on security based activities is also extremely low (disturbances rarely occur).
6. Data access should be restricted to sharing within tradelanes.
7. One tradelane partners expressed the interest in tampering information.

In a separate effort, Customs requirements for the SICIS system have been identified. Together with the INTEGRITY Customs partners, the following list of potential Customs benefits was defined:

1. Access to point of stuffing data in early stage
2. Insight in the secure pipeline and access to security status of partners
3. Identifying authorizations (e.g. for closing the container) – digital signature
4. Possibility to reduce commercial and Customs restrictions in port of arrival
5. Availability of historical data for intelligence gathering
6. Continuous access to data pipeline for risk assessment
7. Facilitating trade on new routes

3.4 Generic document and information exchange

In a generic case, that involves a European importer, who buys FOB from a Chinese manufacturer the chain includes a freight forwarder at origin and at destination. The freight forwarder assumes the cargo responsibility (which includes booking of pre- or on-carriage), Customs broking, and ship booking.

The sequence of activities is as follows:

1. Purchase order received – manufacturing or sourcing takes place
2. Order complete for dispatch → shipper's letter of instruction is sent to forwarder
3. Forwarder initiates ship booking

4. Forwarder initiates transport booking at origin → container pick up, packing list
5. Terminal receives container
6. Origin Customs release
7. Container is loaded
8. Shipping line signs B/L
9. Freight forwarder at origin send data file containing B/L, invoices and other documents to freight forwarder at destination
10. Several days before ship arrival at destination, shipping line signals ETA
11. Freight forwarder at destination performs document check and initiates on-carriage booking
12. Ship arrival → container unloaded
13. Commercial release/Destination Customs release
14. Container pick up for delivery to warehouse
15. Transport operator or warehouse operator generates proof of delivery.

Some important observations in this process are:

1. There are inherent uncertainties in this process, which lead to invisibilities that are difficult to resolve. For instance, the booking of the truck at origin is placed in such a way that the container will be loaded on the right ship in time. This booking is made against a deadline (the cut-off date and time for the ship), but container pick up and delivery can take place somewhere between several days and 5 minutes before that deadline. Exact pick up time at the factory is not agreed in the truck booking or with the factory, and usually remains unrecorded. The truck booking runs from empty container pick up until container delivery at the terminal, for which often 7-10 days is allowed by the shipping line (for the use of the empty container).
2. The main information transfer from origin to destination takes place somewhere around 10 days after ship departure when the freight forwarder at origin sends a file to the freight forwarder at destination. This file includes house and master B/Ls, commercial invoices, certificates and packing lists. This transfer can be done through system-to-system communication, but this does not seem to be very common. In many cases, it is done by email, fax, and regular mail. Considerable administrative effort is spent on checking the accuracy and completeness of this data file.
3. Much of the administrative burden is in the information gathering on ship arrival. Ship arrival is an important deadline for document preparation (transport booking, arrival notification to final destination, Customs declaration), but accurate ship arrival information is notoriously difficult to obtain.
4. The Customs declaration process at destination side contains several steps:
 - a. Initial declaration on basis of ship manifest by shipping line

- b. Completion of declaration for import or transit by ‘Customs broker’ (often freight forwarder)
 - c. Final declaration for import at the warehouse location
- The first two steps leads to the Customs release at the terminal, either directly, or after an inspection activity, which can be asking additional documentation, x-ray, partial inspection or complete inspection of the container. There are costs involved in the inspection activities, and especially full inspection will result in a time delay of up to two days.
5. There can be a considerable difference between minimum required time and actual time spent in the on-carriage part of the chain. In principal, container pick up at the terminal could take place almost immediately after unloading of the container, transportation to a location in the Netherlands by truck, barge or train will not take more than half a day, and unloading and loading at an inland terminal may also take part of a day. On average, even in the intermodal case, on carriage could be completed in two days. In practice, this is not often the case. Some of the delay is due to the documentary process (release of the container may be delayed, and the container is often only considered available for pick up upon departure of the ship, instead of immediately after unloading. Furthermore, time in stack at the terminal may be extended for other reasons: lack of warehouse space, cost and commercial considerations. As a result, estimated lead time for the on-carriage part of the chain can easily be 5 – 10 days.
 6. In several cases, de-gassing of the container is required (due to the fact that some products generate gas in the closed confines of the container). There is usually no advance information if the container needs to be de-gassed, and de-gassing takes time. As a result, the discovery of gas in a container causes a major and immediate bottleneck in the logistics chain. Information exchange between parties (3PL, ultimate user and terminal) could help to find a good location in the chain to perform the gas measurement and possible de-gassing activity.

3.5 Customs requirements

The context for the requirement of Customs for services provided by SICIS is the future vision on Customs operations as discussed with the INTEGRITY Customs partners. In this vision, critical elements are:

- Less transaction based Customs controls at import and export, with a combination of centralised clearance and self assessment making best use of existing trade based data
- A seamless integrated data and logistics ‘pipeline’ focussing on the international trade supply chain and the movement of goods along it rather than an import or an export or goods in transit
- The use of a unique consignment reference number concept to identify the goods, the people associated with the goods and the movement status of the goods
- Data retrieval and risk assessment as early in the chain as possible, and whenever this is deemed necessary, for security and admissibility and providing an effective interface with regulatory requirements such as the Import and Export Control Systems (ICS, ECS)

- Full visibility on the integrity of the chain (parties involved, responsibilities, tampering, inspection activities, routing, accurate data relating to the goods, the geographic position of the goods, security of the goods at all times),
- Development of a single window concept for communication between the entire tradelane and Customs and other supervision organisations,
- Arrangement on the responsibilities for signalling of and responses to security relevant events in the tradelane
- Strategic alignment of the Integrity Project with international Customs developments and UN standards such as the WCO Data Sets, UN/CEFACT, SAFE Framework of Standards, Smart and Secure Trade Lanes, the EU Multi Annual Strategic Plan and the US Safe Port Act including 10+2

The interest of Customs in INTEGRITY centres on the extent to which SICIS and its associated services will support this new and emerging way of operating for Customs and border agencies. The basis for this would be to start from a generic data model, and check to what extent SICIS contains the data elements that are required to fill this data model. The following table contains a summary of how many data elements are captured in SICIS.

	European regulation 1875/2006		SAFE	SSTL	10+2	24 hr rule
	Exit summary declaration	Entry summary declaration	WCO	'Combi-declaration'	USA (carrier)	USA
Total data elements	23	30	36	20	12	17
Basic SICIS	9	13	18	12	11	10
'Extended' SICIS	14	22	27	15	11	14

Tab. 2: Data element capture summary counts

'Extended' SICIS refers to future releases of SICIS with additional features compared to the first release.

From the table it is clear that compared to the WCO data model, SICIS captures a bit more than 50% in the first release, and 80% in the extended version. The data elements that are missing – this holds for all cases - are very Customs specific items, such as tariff code, person lodging the declaration, other circumstances, transport charges method of payment, and some goods description details. This proves that SICIS, if it captures cargo information from either an SLI or packing list, should be very well positioned to help prepare Customs documentation. SICIS is built on open architecture providing a very real opportunity to extend SICIS even further to include all regulatory data requirements later if required.

Another observation is that SICIS, even in the basic version, captures almost all items of the USA 10+2 requirement.

While this data element analysis gives some guidance for the assessment of the potential information content in SICIS, the focus on the usefulness of SICIS for the development towards the future vision also sheds some light on the requirement concerning data preparation for the Customs declaration process. Given that in the future, Customs will move towards less transaction based declarations and more towards making best use of existing commercial based data, features that combine regulatory and logistics data capture along the full extent of the supply chain offer considerable flexibility in meeting the information needs of current and future regulatory systems and add significant value in terms of supply chain visibility.

The very nature of SICS enables data retrieval at any moment between the closing and opening of the container. Given the fact that Customs may have differing data needs based on the risk assessment and specific reason of the search, the best way to make the data in SICIS available is through a web search tool.

The way the feature works depends on the amount of data that is stored in SICIS. If SICIS stores all information on container tracking and cargo content, the data can be made available directly as a result of a query. However, SICIS may capture and store container based data, but not cargo related information. This may only be made available through linkages to the systems where this information is stored.

If this is the case, the core of the query system will have to be the generation of lists of linkages to systems, where various data elements can be found. This information can then be retrieved to present the output of the query. This may result in additional requirement vis-à-vis a query system that goes beyond the normal use by tradelane partners.

In the vision, Customs will retrieve data on the shipment or consignment as early as possible (immediately after the closing of the container), and then continue to assess the integrity of the chain. This information will be provided for, at least, admissibility, security and clearance purposes through, for example, ICS (Import Control System) and ECS (Export Control System). As a result, Customs would be interested in information that pertains to the integrity of the data and logistics chain: exact routing, deviations from this routing, the security status of all parties involved, inspection activities, either by Customs or by the tradelane partners themselves, and any exceptional activity or event that may have occurred. For SICIS to be relevant for Customs, it would have to capture this type of information as well. In addition to this, SICIS will have to contain information on all road haulage and other surface transport operators, and may have to develop protocols that relate exceptions with acceptable corrective actions.

While Customs is currently developing in the direction of the future vision, a number of other inspection agencies are not advancing so fast. Many certificates still have to be presented to the inspection agency in hard copy. The most immediate improvement that SICIS can provide in this respect is to digitise the documents and certificates as soon as they become available, and make these documents available to the inspection.

Finally, an important aspect of the role of SICIS-like systems as one of the main information sources for Customs is the self-regulating role of the tradelane that SICIS contains information on. This includes some degree of self-reporting of the tradelane

partners to Customs on exceptional events, and an agreement with Customs on which activities will compensate for which exceptional event.

4 The SICIS system

SICIS – the Shared Intermodal Container Information System - provides functionality to allow containers to be tracked on tradelanes using a combination of data from Container Security Devices (CSD's) and the participating Terminals e.g. Yantian International Container Terminal (YICT), Europe Combined Terminals (ECT in Rotterdam) and Felixstowe Dock and Railway Company (FDRC).

The basic SICIS system was put 'live' on 14th September, 2009 with the first container starting its journey on 21st September, 2009 and, as an active system, can be demonstrated as required.

This chapter will describe the various functions, interfaces and underlying architecture that has been created to provide the SICIS platform.

4.1 SICIS architecture

Fig. 13 provides an overview of all the features of extended SICIS that have been realized during the course of the INTEGRITY project. The roll-out of the SICIS system is marked by progressive system features in three phases: basic SICIS, extended SICIS, and foreseen features. The figure shows a six-layered model of SICIS features, where the features in the top three layers build upon the features in the lower three layers.

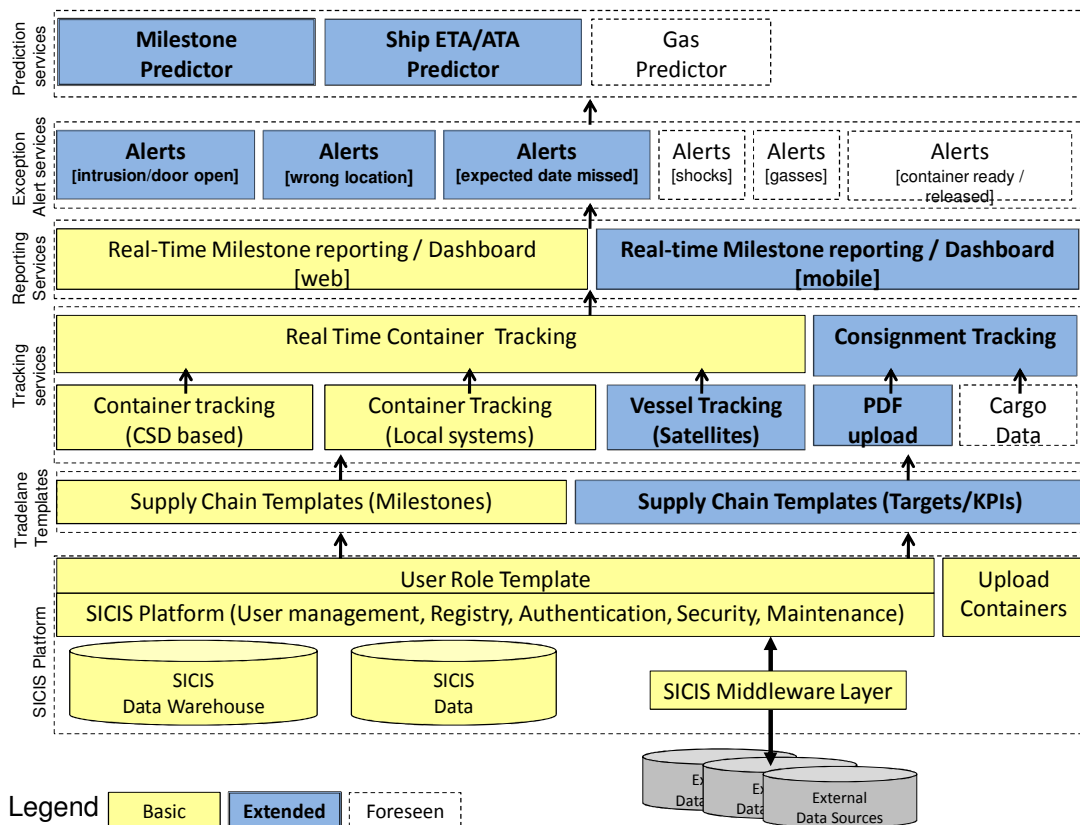

Fig. 13: Features of basic, extended, and foreseen SICIS

We indeed distinguish six levels of features:

- (1) SICIS platform This includes user management, data access governance, middleware (data feeds to/from other systems) and a possibility to upload a set of containers in SICIS.
- (2) Trade lane Templates Modelling of chain of custody, trade lane milestones and target/KPI values, which can be used to generate exception alerts.
- (3) Tracking Services Services include:
 - a. *real time tracking of containers* based on data capture via container security devices, (terminal) databases, and manual data upload functionalities. This includes records of whether Customs scanning or inspection activities have taken place in Port of Loading
 - b. *tracking of consignments*, based on manual PDF upload functionalities. In the future this can be supplemented with consignment data, based on connections with other systems that contain such information (like ePort, port community systems) or direct links to shippers or forwarders.
- (4) Reporting services: *real-time milestone reporting* provides the milestone data collected in the supply chain for each container, i.e. the timing of the occurrence of the milestone event. The milestone data are retrieved either before the relevant events as an expected time or planned time, or after the event as an actual time. Reporting services can be accessed via the web or via a mobile device.
- (5) Exception alert services: These services generate alerts that are induced by exceptions or disruptions, usually a deviation between actual and target performance or status. The alerts may be driven by events which are not planned or which show performance below target, by the absence of planned events, etc. The alerts are sent via

e-mail or a mobile device. Exception alerts are available on mile-stone deviations (i.e. wrong location or expected data missed) and in case of door-open disruptions (based on CSD). Possible future extensions include *container readiness alerts* for Customs and Commercial release.

(6) Prediction services: An example of a prediction or prognostic service is the *Milestone predictor*, which adjusts expectations of Milestone dates after observed deviations from earlier milestones in the trade lane template. In particular, the ETA Warner discussed in D4.5 would provide a *ship arrival prediction* feature, combining real-time vessel position data (based on a.o. AIS), shipping liner schedules, and an intelligent module to determine the reliability of ETA provided or forecast ETA. Another possible future service could be a module which predicts *toxic levels of gas when the container is to be opened*, based on sensor readings from the container security device. Prediction services can assist SICIS users in their planning process.

4.2 Existing information exchange and SICIS

The following is a generic description of a supply chain: details may change for case to case.

The shipment of cargo is initiated by sending a purchase order from a buyer to a seller, the latter of which will forward this purchase order to the factory who will provide the product. The payment arrangement is then set in motion, by means of letters of credit, who will become payable upon shipment of the goods. The proof of shipment is the signed copy of the bill of lading from the ship that has taken the goods on board.

Depending on the exact arrangement of who takes care of the transport bookings, the factory sends a Shipper's Letter of Instruction (SLI) of equivalent document (Forwarder's Instruction) to the freight forwarder. The freight forwarder will then start booking transportation, starting with the ship, and then pre-carriage and on-carriage. If the buyer retains its own freight forwarder, this forwarder will start setting things in motion upon receiving information on the departure of the ship in the port of loading, and the announcement of the pending arrival of the ship in the port of discharge.

The SLI will record when the cargo can be picked up (before ...- date), and the freight forwarder will send an appropriate pick up notice to the transport operator with instructions to pick up the container, possibly first picking up an empty container, and deliver at the terminal. The transport operator will receive the packing list (PL) with the container, and this packing list will also be sent to the seller, the freight forwarder, and eventually the buyer. The same information was already sent to the freight forwarder through the SLI.

At the terminal, the transport operator will hand over the pick up document, or truck booking notice, and the terminal will verify or record the container number and the seal number.

The loading process commences upon arrival of the ship. When loading is completed, the ship's first mate signs the bill's of lading which set the payment process in motion (in the case of FOB trade terms). During loading and unloading, container numbers and seal numbers are verified.

The truck operator who arrives in the terminal of discharge to pick up the container also hands over a pick up notice or truck booking document, and types in a PIN number to pick

up the container. The terminal verifies container number and seal number up departure of the truck with container. In case hinterland transport includes an intermodal connection to an inland terminal, the process of arrival check and departure check takes place one extra time.

When the truck arrives at the warehouse, the warehouse operator again verifies container number and seal number, and opens up the container for stripping.

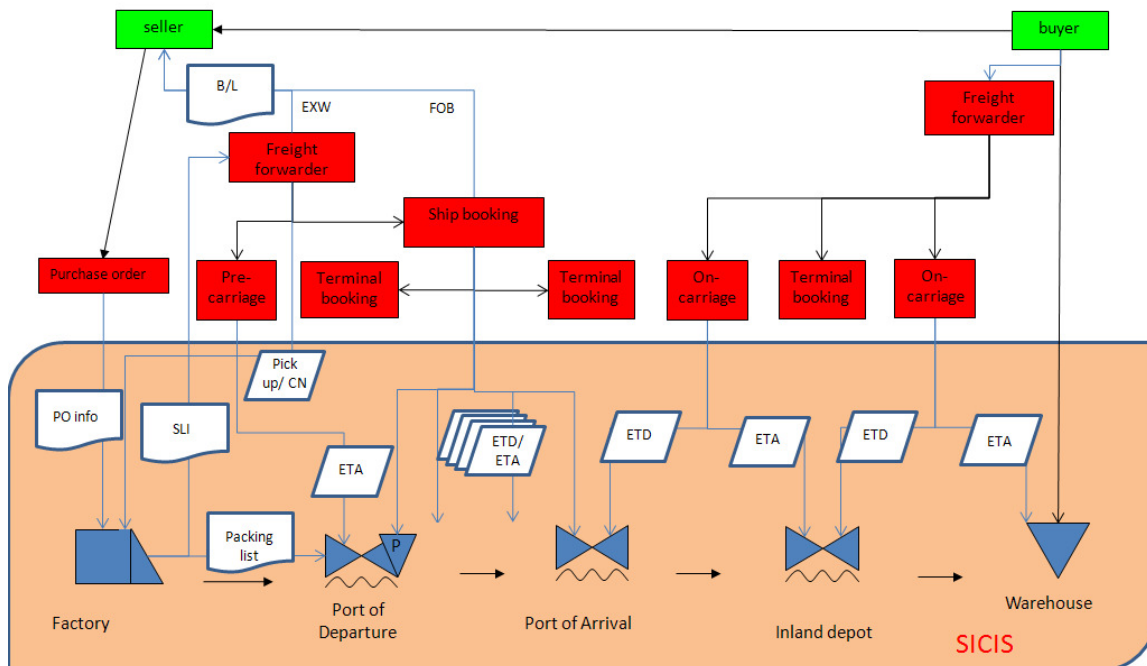

Fig. 14: Information flow relevant for SICIS

The information flow in the commercial and booking process and the resulting information input in SICIS are depicted in Fig. 14. The pink rectangle defines the contours of the SICIS system. SICIS is thus not a platform to support the commercial process (such as Tradecard), or a logistics chain booking platform, such as GT Nexus or INTTRA are for parts of the container chain.

In principle, SICIS captures the expected arrival and departure times from the booking process, although this information may not be captured directly from the booking process, but via the systems of the responsible party (the freight forwarder or booking agent) or the cargo owner (our user). In addition, SICIS captures information at the beginning of the chain.

The bare minimum of information to be captured is the combination of the purchase order (PO) number and the container number (CN). The purchase order number will allow reporting back to the user, while the container number will allow the capturing of actual arrival and departure information. In addition, together with the purchase order number, more detailed information can be captured on the cargo. This is often information that will appear on more than one document: purchase order, packing list, Customs declarations, transport documents. The degree to which this information will actually be captured in SICIS is an issue that the users will have to decide, based on competition considerations, data quality, availability, logistics efficiency and so on.

There are a number of scenarios to capture the basic PO and CN combination:

1. The user provides them both in an initial stage
2. The user provides PO and SICIS captures CN from SLI
3. The user provides PO and SICIS captures CN from PL
4. The user provides PO and SICIS captures CN from Freight forwarder
5. The user provides PO and SICIS captures CN from a visibility system
6. The user provides PO and SICIS captures CN from another party in the chain

These scenarios also exist in analogue for the capturing of cargo information in SICIS. The following figure makes a stricter separation between information provided into SICIS (the blocks at the top) and the information generated in the chain, and captured in SICIS (the blocks at the bottom).

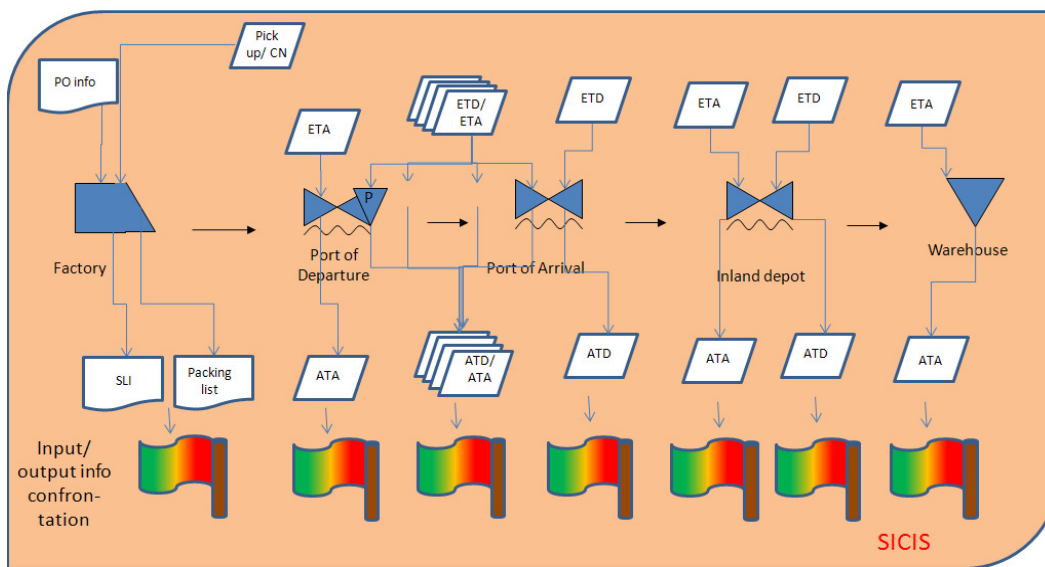

Fig. 15: Information input and output in SICIS

While SICIS is fed with PO+CN and ETD/ETA information, which is all known, in principle, before the container actually starts moving, the chain will generate new information along the way: first the SLI, then the PL, then a series of ATA and ATD information. The date stamps of the SLI and PL can also be considered milestones.

4.3 Container Journey

Information on container journeys can be provided to basic SICIS from the following sources:

- Users directly on the SICIS website
- Messaging via the interface to Terminal Systems
- Messaging via an interface to CSD suppliers.

A variety of sources can be used for any given container. A journey can be started by a website transaction or from a message from a CSD. It can be updated by messages from a terminal or from CSD's and the journey completed via the website or the CSD. The milestones covered in the basic SICIS and the potential sources are:

Milestone	Source
Start Journey	SICIS Website, CSD
Leave factory	SICIS Website, CSD
Arrive port	SICIS Website, Terminals , CSD
Load to ship	SICIS Website, Terminals , CSD
Container discharge	SICIS Website, Terminals, CSD
Outgate from port	SICIS Website, Terminals , CSD
Arrival destination	SICIS Website, CSD
End Journey	SICIS Website, CSD

Tab. 3: Data sources for the SICIS milestones

4.4 Container Query

This function allows users to enquire on the latest information for their containers using a variety of selection criteria at both a 'one line summary' and detailed view level e.g.

One Line Summary

Container No.	Trip Startup	Last Report ^z A↓	Last Location	Last Event
PONU0955680	09-12-2009 14:17	06-01-2010 01:59	PFL Trinity Terminal	Unloading
MSKU6697222	10-12-2009 20:54	06-01-2010 01:48	PFL Trinity Terminal	Unloading
MIEU4501030	09-12-2009 17:16	06-01-2010 00:15	PFL Trinity Terminal	Unloading
POCU3005796	09-12-2009 05:01	05-01-2010 23:36	PFL Trinity Terminal	Unloading
ECMU9176071	31-12-2009 03:21	05-01-2010 20:02	Yantian International Container Terminal	Loading
MSKU6326258	29-12-2009 13:03	03-01-2010 17:37	Yantian International Container Terminal	Loading
MSKU7622418	29-12-2009 15:11	03-01-2010 16:50	Yantian International Container Terminal	Loading

▶ | ▶▶

Fig. 16: Overview of monitored containers

Detail View

Role	Role Category	Date	Time	Event	Location	Supplied By
Forwarder	Destination					
Logistics service provider (import side)	Destination	09-11-2009	15:00	Container Opening / end Journey	BAP WAREHOUSE	SICIS
Terminal operator	Destination	05-11-2009	10:13	Gate Out	PFL Trinity Terminal	SICIS
		03-11-2009	00:53	Unloading	PFL Trinity Terminal	HDN
Shipping line	Origin					
Terminal operator	Origin	10-10-2009	20:36	Loading	Yantian International Container Terminal	HDN
		10-10-2009	05:50	Gate In	Yantian International Container Terminal	HDN
Forwarder	Origin	10-10-2009	03:30	Closing Container / Initiate Tracking	CARGO SERVICE YANTIAN WAREHOUSE	SICIS

Fig. 17: Detail view of a container

4.5 Container Information

The container information is updated with data about the vessel it has been loaded onto so that the information is all brought together for the user in one place.

The following screen is the ‘Summary’ showing the latest information for containers meeting a particular set of search criteria.

Container Movement List									
Active Container		Completed Container		All Container					
★	<input type="checkbox"/> Container No.	Trip Startup	Last Report	Last Location	Last Event	Vessel Name	Next Event	Location	Date/Time
1	<input type="checkbox"/> HJCU2180286	02-07-2010 03:08	08-07-2010 11:16	Yantian International Container Terminal	Loading	COSCO CHINA	Estimated Time Arrival	Felixstowe - Trinity	02-08-2010 20:00
2	<input type="checkbox"/> TRLU8863915	19-07-2010 03:56	24-07-2010 16:44	Yantian International Container Terminal	Loading	HANJIN XIAMEN			
3	<input type="checkbox"/> INBU5296553	02-07-2010 03:18	08-07-2010 09:30	Yantian International Container Terminal	Loading	COSCO CHINA	Estimated Time Arrival	Felixstowe - Trinity	02-08-2010 20:00
4	<input type="checkbox"/> CRSU1407888	24-07-2010 04:09	30-07-2010 06:58	Yantian International Container Terminal	Loading	COSCO GUANGZHOU			
5	<input type="checkbox"/> MSCU4360866	03-07-2010 08:12	09-07-2010 20:24	Yantian International Container Terminal	Loading	MSC MELATILDE	Estimated Time Arrival	Felixstowe - Trinity	05-08-2010 16:00
6	<input type="checkbox"/> MSCU4271049	01-07-2010 07:10	09-07-2010 22:12	Yantian International Container Terminal	Loading	MSC MELATILDE	Estimated Time Arrival	Felixstowe - Trinity	05-08-2010 16:00
7	<input type="checkbox"/> MEDU2051437	30-06-2010 07:03	09-07-2010 18:54	Yantian International Container Terminal	Loading	MSC MELATILDE	Estimated Time Arrival	Felixstowe - Trinity	05-08-2010 16:00

Fig. 18: Container movement list

Each container number is a hyperlink and provides access to more detailed data about that container.

N/A	N/A	23-06-2010 05:45	Container Opening / end Journey		Savitrak- GPS	23-06-2010 05:47								
N/A	N/A	23-06-2010 05:15	Arrival		Savitrak- GPS	23-06-2010 05:47								
Terminal operator	Destination	23-06-2010 04:20	At Gate	Europe Container Terminals	Savitrak- Rfid	23-06-2010 04:22								
Terminal operator	Destination	23-06-2010 02:15	Depart	Europe Container Terminals	Savitrak- GPS	23-06-2010 04:22								
Terminal operator	Destination	19-06-2010 22:50	Unloading	Europe Container Terminals	HDN	20-06-2010 00:17			MOL PACE	3EDR7	9321017	371701000		
Terminal operator	Destination	19-06-2010 21:45	Arrival	Europe Container Terminals	Savitrak- GPS	19-06-2010 22:17								
Terminal operator	Destination	19-06-2010 21:39	At shipside	Europe Container Terminals	Savitrak- Rfid	19-06-2010 21:42								
N/A	N/A	19-06-2010 12:15	At Checkpoint		Savitrak- GPS	19-06-2010 18:17								
N/A	N/A	16-06-2010 15:45	At Checkpoint	Strait of Gibraltar	Savitrak- GPS	19-06-2010 18:17								
N/A	N/A	16-06-2010 15:15	Depart		Savitrak- GPS	19-06-2010 18:17								
N/A	N/A	16-06-2010 05:45	Arrival		Savitrak- GPS	16-06-2010 06:17								
N/A	N/A	16-06-2010 02:45	At Checkpoint	Strait of Gibraltar	Savitrak- GPS	16-06-2010 06:17								
N/A	N/A	11-06-2010 13:45	At Checkpoint		Savitrak- GPS	11-06-2010 14:17								
N/A	N/A	08-06-2010 06:15	At Checkpoint	Strait of Djibouti	Savitrak- GPS	10-06-2010 14:18								
N/A	N/A	31-05-2010 04:45	At Checkpoint	Malacca Strait	Savitrak- GPS	31-05-2010 06:17								
N/A	N/A	31-05-2010 02:15	Depart	Singapore	Savitrak- GPS	31-05-2010 02:17								
N/A	N/A	30-05-2010 07:45	Arrival	Singapore	Savitrak- GPS	30-05-2010 10:17								
N/A	N/A	30-05-2010 00:45	At Checkpoint	Strait of Singapore	Savitrak- GPS	30-05-2010 02:17								
N/A	N/A	27-05-2010 02:15	Depart	Yantian International Container Terminal	Savitrak- GPS	27-05-2010 02:17								
		26-05-2010 18:00	Estimated Time Departure	Yantian International Container Terminal	HDN	25-05-2010 22:35			MOL PACE	3EDR7	9321017			
N/A	N/A	26-05-2010 10:45	Arrival	Yantian International Container Terminal	Savitrak- GPS	26-05-2010 14:17								
Terminal operator	Origin	26-05-2010 06:45	Depart	HIT Terminal	Savitrak- GPS	26-05-2010 10:17								
		26-05-2010 04:00	Estimated Time Arrival	Yantian International Container Terminal	HDN	25-05-2010 22:35			MOL PACE	3EDR7	9321017			
N/A	N/A	26-05-2010 02:01	Loading	HIT Terminal 4	HDN	26-05-2010 02:25	664321		MOL PACE	3EDR7	9321017	371701000		
N/A	N/A	22-05-2010 06:39	Gate In	HIT Terminal 4	HDN	22-05-2010 08:20	664321		MOL PACE	3EDR7	9321017	371701000		
Terminal operator	Origin	22-05-2010 06:38	Arrival	HIT Terminal	Savitrak- GPS	22-05-2010 06:42								
Consolidator (export side)	Origin	22-05-2010 06:12	Close Container, Initiate Tracking	DHL GF Hong Kong	Savitrak- GPS	22-05-2010 06:19								

Fig. 19: Detailed milestone data of a container

4.6 Container tracking

Using the location information received SICIS can track the container using a ‘Google map’ view.

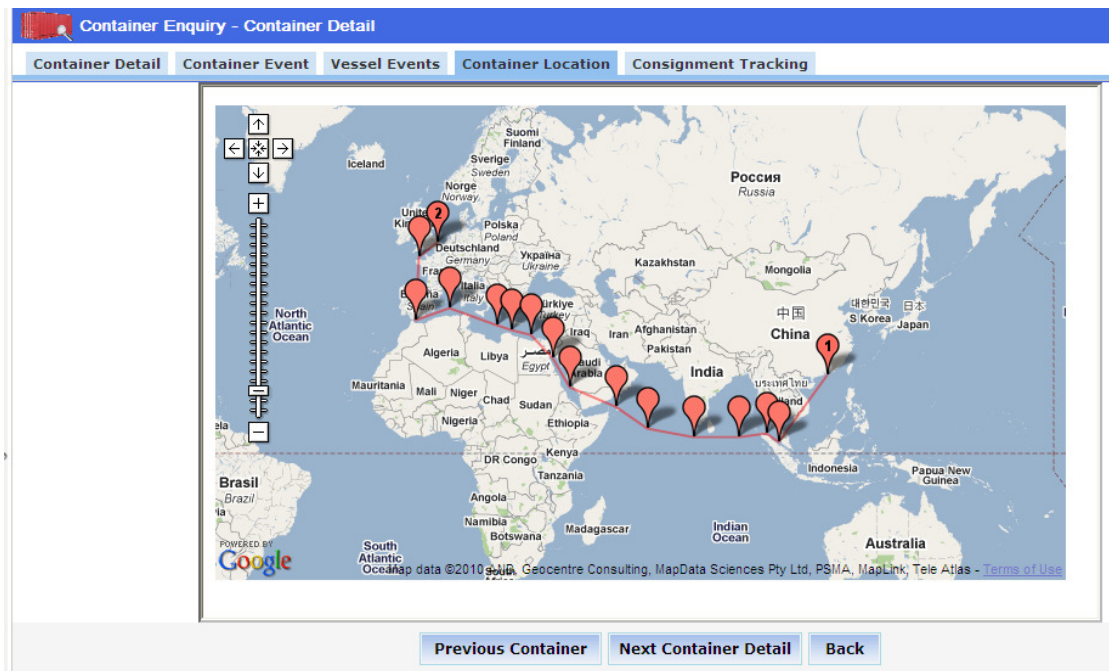

Fig. 20: Map view of a container’s journey

4.7 Consignment Level Information

SICIS includes functions to allow ‘Trade Lane Owners’ to add the consignment information in the form of image or Adobe files for each container. There are three basic parts to this which are described in the sections below.

4.7.1 Document Upload

The Trade Lane Owner can use a new facility to upload a document or documents against a container record. To reflect normal shipping practice many documents can be added against a single container and one document can be used for many containers.

The user is required to enter a consignment or document reference number and then use standard browser options to select the appropriate file from their own systems.

4.7.2 Search and access to Consignment Information

The Container Query function has been changed to add a search for consignment reference number.

Fig. 21: Container enquiry screen

This will give a list of all the containers with this reference number (subject to the users authorisation).

The user can then select an appropriate container and view the details.

Role	Role Category	Company Code	Company Name
1 Consolidator (export side)	Origin	bafact	BA fact
2 Forwarder	Origin	BACN	BA asia
3 Terminal operator	Origin	CMP_YICT	YICT
4 Importer	Destination	badc	BADC
5 Terminal operator	Destination	ST_CMP_10	ST_CMP_10
6 Forwarder	Destination	baeuro	BA europe

Consignment Reference No.	Company Name	Document Type	File
BA111	BA TLO		ASN2010083265a12ef-6.pdf
BA110	BA TLO	ASN	A5622010CNTYM.pdf

Role	Role Category	Date	Time	Event	Location
Terminal operator	Origin	03-08-2010	19:52	Loading	Yantian International Container Terminal
Terminal operator	Origin	02-08-2010	02:51	Gate In	Yantian International Container Terminal
Consolidator (export side)	Origin	01-08-2010	01:16	Closing Container / Initiate Tracking	BA Fact

Consignment Reference No.	Company Name	Document Type	File
BA112	BA TLO	DECLARE	Entry 0711035461008231413.JP

Fig. 22: Container detail view

This screen has been designed to allow Customs (any any other authorities) an 'overview' of the consignment:

- Parties Involved. This is a copy of the Template to which the container is attached. The 'Company code' field will be changed in a later release so that it shows the companies Customs Authorisations (AEO etc.) which are held on the Registration page. The 'Company Name' will be changed to a hyperlink giving a pop up window showing the full company details.
- Cargo detail. This gives Customs and the Trade Lane Owner access to the document by clicking on the hyperlink. Note – no other users have this access
- Tracking summary. This lists the events that have been received for the this container as it is tracked on it journey.
- Further Declaration Details. If multiple documents have been loaded for the container then they are shown here.

4.8 Vessel Information

Vessel information can be accepted from port systems and from the vessels own Automatic Identification System (AIS).

The Automatic Identification System is a ship tracking network using VHF transponders on the two frequencies 161,975 MHz and 162,025 MHz. Every ship above 300 tons needs to have embarked an AIS transmitter until 2008 based on IMO regulation of 1998 which emits around 20 parameters periodically in the VHF band

AIS equipped ships are transmitting their positions, destinations, names, cargo types, and different types of additional information. AIS transponders and receivers output the received information as serial data using AIVDM messages. These are described in the IEC 61993-2 specification, but they are very similar to NMEA 0813 messages output by GPS devices.

Terrestrial AIS receiving stations are operated by local country authorities to monitor and control the traffic within the territorial waters. Beside these governmental applications private companies offer AIS value added services (AISLive, Vesseltracker).

The US Coast Guard considers ORBCOMM satellite constellation allowing the capture of the AIS signal as most promising solution to fulfil law requirements allowing even extension of ship monitoring to global level. A first contract to demonstrate technologies was passed to ORBCOMM. Six new satellites with AIS payload in orbit since 19.6.2008. On January, 16th, 2009, OHB and ESA have signed a contract regarding the analysis and design for an European AIS satellite constellation for vessel tracking. The upcoming Service provided by OHB will integrate both, satellite based and terrestrial AIS data.

When a container is loaded to ship the message received by SICIS includes the vessel details and these can be checked against a standardised list of vessels (to check for possible errors). For the prototype this list is held within SICIS but, in a production system external vessel lists such as Fairplay could be used.

Vessel List Maintenance

Vessel Name Call Sign

UN Number MMSI

Vessel List

	<input type="checkbox"/> Vessel Name	Call Sign	UN Number	MMSI	Status	Remarks
1	<input type="checkbox"/> AEGEAN EXPRESS	3FVV7	9138161	351563000	Active	
2	<input type="checkbox"/> ALBERT MAERSK	OUOW2	9260469	220263000	Active	
3	<input type="checkbox"/> APL AUSTRIA	A8NC5	9444285	636013457	Active	
4	<input type="checkbox"/> APL COSTA RICA	DEDG	9105918	218745000	Active	
5	<input type="checkbox"/> APL DALLAS	A8NY8	9345984	636091448	Active	
6	<input type="checkbox"/> APL EARNEST	3EMD3	9333840	351496000	Active	
7	<input type="checkbox"/> APL KAOHSIUNG	V2MK	9235074	304150000	Active	

Fig. 23: Vessel list

The first container to be loaded to a ship puts it onto a 'Vessel Watch List' in SICIS and this Watch List is sent regularly to information providers. The prototype currently obtains information from Integrity partners HPH who host the 'Hutchison Data Network' (HDN) and OHB which obtains AIS data but discussions are underway to widen the scope of this.

Vessel Watch List Enquiry VW00

Vessel Name Call Sign

UN Number MMSI

Vessel Watch List

	<input type="checkbox"/> Vessel Name	Call Sign	UN Number	MMSI	No. of Active Container
1	<input type="checkbox"/> APL AUSTRIA	A8NC5	9444285	636013457	3
2	<input type="checkbox"/> APL FRANCE	C6WN8	9321249	308015000	5
3	<input type="checkbox"/> APL POLAND	C6WX5	9321263	311001700	4
4	<input type="checkbox"/> COSCO CHINA	A8GP4	9305465	636090843	2
5	<input type="checkbox"/> COSCO GUANGZHOU	SYIE	9305570	240475000	1
6	<input type="checkbox"/> HANJIN XIAMEN	3EJL6	9312755	372557000	1
7	<input type="checkbox"/> HYUNDAI COURAGE	3ENU4	9347542	352698000	1

Fig. 24: Vessel watch list

The terminals routinely send vessel information in the form of Estimated Times of Arrival (ETA's) actual arrival and departure times for all vessels. Using the Watch List provided by SICIS this information and relevant updates are made available in SICIS. OHB sends AIS data to SICIS for vessels on the Watch List using a similar mechanism.

To cater for possible errors and provide a back up facility SICIS also contains web based facilities to create vessel events directly on the system.

Vessel Event Create

*Required Information

Vessel Name	Call Sign	UN Number	MMSI	*Event Code	Event Location	*Event Date Time
MOL DREAM ...	V2MH	9220328	30424200	Estimated Tim	ECT Delta Ter	
...						
...						
...						
...						
...						

05-08-2010 11:56 X

<< < Today > >>

Sun	Mon	Tue	Wed	Thu	Fri	Sat
32	1	2	3	4	5	6
33	8	9	10	11	12	13
34	15	16	17	18	19	20
35	22	23	24	25	26	27
36	29	30	31	1	2	3

11 :56 :00 OK

Append Row OK Cancel

Fig. 25: Manual creation of vessel events

When the vessels arrive in Europe SICIS receives unload or discharge information for each container. When the last container is discharged SICIS removes the vessel from the Watch List.

4.9 Container Security Devices

4.9.1 Savi Networks

The Savi Networks CSD is a device which is mounted on the container door by pushing it over the edge of the container door. It consists of two parts. One part which contains the antennas is located outside the container while the other part containing the electronics and sensors is located inside the container.

When a container security device is used to start, track and end a container voyage, the only task an employee on site has to perform is to attach a container security device to the container just before the door are closed. It cannot be done after sealing a container without breaking the seal. The task to attach a device is as follows: The CSD is to be activated by exchanging a red and a green port cap as described below.



Fig. 26: Initialisation of a Savi Networks CSD

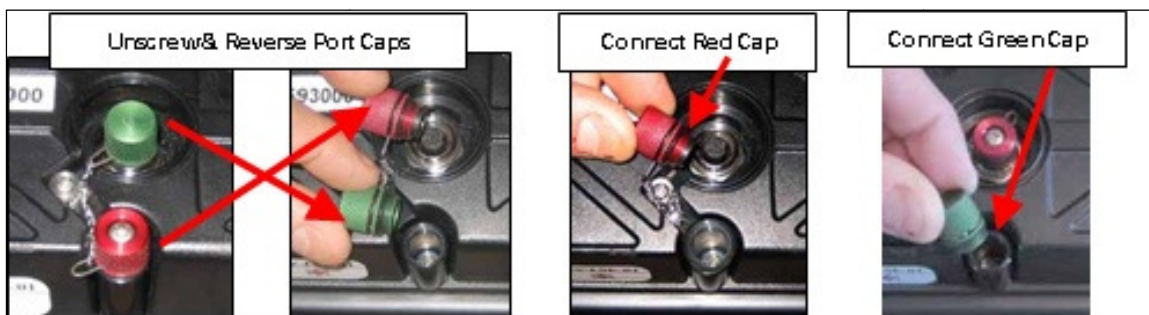

Fig. 27: Activation of a Savi Networks CSD

Description provided by SAVI Networks.

After this the device should be exposed to the open sky for about 10 minutes enabling acquiring the first GPS position. This action should be done just before attaching the CSD to the left container door of the container in question and the container should be closed immediately. Subsequently a handheld device is used to lock the CSD according to the user manual and training given. Then the usual container handling is performed – ex. sealing and immediate leave of premises or storing on premises for later dispatch.

4.9.2 LongSun

The Longsun device is a ‘padlock’ type design that was already in use within China and is used to verify that a container has not been opened between the original loading point and the seaport. Between these two points the container may cross a number of internal Chinese Customs borders and the device provides the authorities with proof of non intrusion.

However the design makes it unsuitable for loading onto ships because, when attached to a container, it sticks out making it prone to damage from other containers or from the ships structure.

As a result trials were run with a number of containers between the loading point and in Yantian Container Terminal gates where the devices were removed. An interesting feature of these devices was the combination of a physical as well as an electronic lock.



Fig. 28: LongSun CSD

When the device is fixed to a container it is locked with a normal physical key. A Handheld device is then used to set the electronic lock. On completion of this process the lock cannot be opened with a physical key alone; an electronic signal is required before the locking mechanism releases. The device sets itself to ‘Intrusion’ state if this process is not followed.

During the INTEGRITY demonstration, handheld readers were used by the Yantian Gate staff to read the LongSun devices upon container arrival at the in-gate area, collecting the

device number and status. The electronic unlock signal is then sent and the Yantian Gate staff then use a dedicated physical key to remove the device.

The interface between SICIS and LongSun's system used the same interface as developed for SaviNetworks.

4.9.3 CIMC

The CIMC device is attached to the container door handle and uses a bolt seal with an extended pin to secure it to the sealing point on the handle. It is designed with a narrow profile making it suitable for all normal container handling operations including load/discharge to ships. The device is, therefore, able to be used from origin all the way through to destination.



Fig. 29: CIMC CSD

Trials were conducted with CIMC devices in the summer of 2010 but at this stage they had no GPS capability and could only provide a 'Start Journey', 'End Journey' and, if the device was read with a handheld during the trip, the tamper status could be obtained.

Following the loss of the SaviNetworks devices negotiations were conducted with CIMC and agreement reached to provide Integrity with additional devices. For the first month (March 2011) these would be the original devices without GPS and, at the end of March CIMC would provide the first GPS enabled devices. The first non GPS devices were fixed to Xerox containers in March with the first GPS devices being fixed to DHL and BAP containers in early April.

Once again, the interface developed for SaviNetworks was used to communicate with CIMC.

It was found that the CIMC technology required someone to use a hand held computer at the destination point to 'tell' the system that the journey has been completed. This was seen as a retrograde step as the SaviNetwork system had used geo fencing to interpret a container opening inside the destination site as an 'End Journey' . To compensate for this the SICIS existing geo fencing capability was enhanced so that, when a Open event is received from a CSD, SICIS will check the Lat/Long and, if it is inside the destination area, it is treated as an End Journey.

4.9.4 CHINOS

CHINOS is the acronym for the project "Container Handling in Intermodal Nodes – Optimal and Secure!". The project duration was from 2006 until 2009 and was coordinated by the Institute of Shipping Economics and Logistics and was supported by the European Commission in the 6th Framework Programme.

The system which has been developed in the run of the project aims to identify container and the status of an attached electronic seal (eSeal) in an automatically manner in order to create realtime events of the transportation flow.

The CHINOS system consists of an electronic RFID transponder (also referred to as a Tag) attached to the container, able to provide positive unambiguous identification of a container. An sSeal uses the current mechanically robust door seal mechanisms but adds the electronic RFID technology to enable seal identification and additional tamperproof electronic security to the device.

On the one hand the data quality provided by CSDs cannot be achieved by other means. But on the other hand usage of CSDs is very costly and equipping each and every container with a CSD in the near future is unlikely.

The approach in INTEGRITY is in no way dependent on the usage of CSD. Therefore, a manual start process has been implemented in order to track containers which are not equipped with CSDs and are just using traditional bolt seals.

User of SICIS can select between the usage of cheap traditional bolt seals with limited security and costly CSDs offering different features on tracking containers and security.

In order to fill the gap between these two options the CHINOS system with its container tags and eSeals has been used during INTEGRITY demonstration phase. On the one hand CHINOS eSeals are cheaper than CSDs but on the other hand they can increase the security of the container transport and offer more tracking abilities than traditional bolt seals.



Fig. 30: CHINOS handheld with integrated container RFID tag and eSeal reader

5 The SICIS demonstration phase

The execution of INTEGRITY Demonstration with SICIS is described in this chapter from the view of a user on site either concerned with finishing containers or being in front of a

computer and working with SICIS. Both roles can be performed by a single person of any one company. This part is combined with some background information for better understanding.

5.1 General information

Execution of basic demonstration started with the initial rollout with the first version of SICIS available on the intended production environment from September 14th 2009 until the second SICIS version took over on November 23rd, 2009. The database was not changed when new SICIS versions were activated.

Container start inside mainland China and are transported to a deep sea container terminal. Inside the terminal containers wait for a load on vessel and are transported to the port of discharge in Europe. From there an on-haulage to destination sites was performed.

The route each container takes in real life cannot be determined beforehand, depending on shipowners right to (re-) direct vessels and taking current piracy activities into account, vessels could be directed completely around Africa avoiding the Suez-Canal and adjacent waters. This alternative routeing 'costs' about 10 extra days of sailing.

Such information must be taken into account when executing demonstration. One example to take alternative routing into account is battery lifetime of CSDs: Data becomes less useful if the whole voyage is recorded, but the two vital waypoints for participating European container terminals (entry and exit of the Bay of Biscay) are missed because of empty batteries due to a lengthened container voyage.

5.2 Tasks performed by users of the system

The execution of the demonstration is divided into two parts which tradelane partners (or more commonly the users of the system) have to perform in order to use the system to the intended extent. The first part to be performed is setting up the system for a companies use, the second part is to start containers with the system whenever a physical container starts its individual voyage. The voyage could be started with or without the use of other systems.

5.2.1 Start Container Journey by using a SAVI Container Security Device

When a container security device is used to start, track and end a container voyage, the only task an employee on site has to perform is to attach a container security device to the container just before the door are closed. It cannot be done after sealing a container without breaking the seal. The task to attach a device is as follows (using the SAVI CSDs): The CSD is to be activated by exchanging a red and a green port cap as described in the basic demonstration user guide and below.

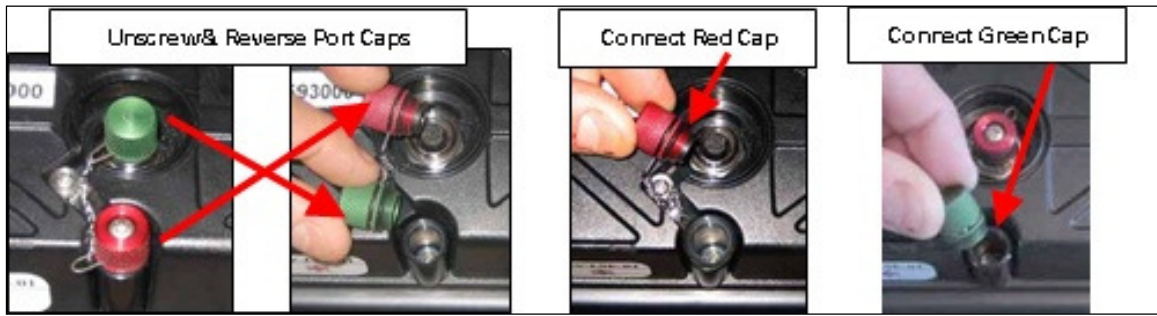

Fig. 31: Activation of the CSD

Description provided by SAVI Networks.

After this the device should be exposed to the open sky for about 10 minutes enabling acquiring the first GPS position. This action should be done just before attaching the CSD to the left container door of the container in question and the container should be closed immediately. Subsequently a handheld device is used to lock the CSD according to the user manual and training given. Then the usual container handling is performed – ex. sealing and immediate leave of premises or storing on premises for later dispatch.

Just these three steps are minimal extra work but have large effects on the surveillance of a container. After locking the CSD it sends a message to the server which contains date, time, exact position gained via GPS-signals and the current security status of the device. Within minutes this information should be visible in the SICIS container enquiry.

5.2.2 Start Container Journey by manual data input

If there is no CSD or Hand Held available the Start Journey function on SICIS should be used instead.

When a container is ready to depart or has already departed the employee in charge should connect to SICIS, enter a minimal data set and the container is known to SICIS immediately.

There are some disadvantages in not using a CSD for a container voyage: in SICIS there is a reduced data set available for this container. If a transshipment is performed in a non-Hutchison Terminal the discharge from vessel and next load on vessel is not recorded. Nor is all the data a CSD provides: Heartbeat messages and door open messages. Another disadvantage is the needed manual data input to end a container voyage in SICIS, which should be done by the receiving party.

5.2.3 During a Container Voyage

In general there is no extra work to be executed during a container voyage whether using a CSD or not since all the data inputs to SICIS are acquired automatically from the CSD provider or HDN.

5.2.3.1 Using a CSD

During a container voyage there is no extra work to be done for maintenance of the CSD or for the tracking of a container if a CSD is attached. Even container examinations by authorities do not endanger the system.

Pre-haulage from manufacturer to first container terminal and on-haulage from last container terminal to the receiver of a container was done by road haulage in this demonstration. The main haulage from China to Europe was executed using deep sea vessels.

When a CSD is used and a container examination is requested (e.g. by national Customs authorities), the system is able to classify the respective alert: the SAVI CSD sends an open door alert immediately with date, time, exact GPS-position and the flag 'door open alert'. This data is sent whenever the container door is opened and cannot be suppressed. The data received by SaviTrak™ is then interpreted by the software running on the server which has the usual cargo inspection sites of Customs authorities stored. If a door open alert is set from within these geo-fenced areas the open door alert is classified as a Customs opening and forwarded to SICIS. If a door open alert is set from outside of the geo-fenced areas the open door alert is classified as a seal breach and forwarded to SICIS. When authorities perform an examination of a container outside their usual SaviTrak™ geo-fenced locations this door open alert is forwarded to SICIS as an open door alert to inform respective parties of this unusual event.

Position data shown in SICIS during a container voyage is gained by a CSD if attached and HDN-Messages. This information is forwarded to SICIS and can be checked by authorised SICIS users.

Data from these two different information systems are fed automatically into SICIS. Data from HDN is available most times just minutes after the event occurred, e.g. a load on vessel in the port of loading.

5.2.3.2 Using no CSD

During a container voyage there is no extra work to be done for the tracking of a container if the container is tracked by the different systems named. When no CSD is attached an authority check is done as usual – no extra preparation or postprocessing is needed. On the other hand an internal check can be recognised when a container arrives at its destination, seldom beforehand.

5.2.4 Finalise a container at the point of destination

Opening a container the first time at the destination location in Europe (not Customs open) is the container voyage end in terms of SICIS. According to the different start container journey possibilities, two different tasks to be done are feasible: removing the CSD or ending the container voyage manually in SICIS depending on individual situation of the container.

5.2.4.1 End Container Journey by manual data input

When no CSD is used for a container journey the end container journey is done by inserting the information directly into SICIS. In order to perform this task, a user has to

connect to the software using user name and password, chose the end container journey data input, enters container number, date, time and location and, if possible, a few more items of information and confirms this event. This solution might be used in case of a missing or broken down CSD as well. CSDs might be missing if sheared off by rough container handling.

5.2.4.2 End Container Journey by removing CSD

When a CSD is attached to a container and the container is to be opened, the employee should remove the CSD from the left container door immediately after opening and expose the CSD to the open sky for about 10 minutes. After this period the red and green caps are to be exchanged in order to deactivate the CSD. The device should immediately be stored in a carton delivered beforehand by SAVI Networks. The provider will also arrange for a parcels carrier to collect the full cartons. The removal is detected by the CSD itself and it sends an open door alert with date, time and the GPS position to the SaviTrak™ server. This message is subsequently interpreted by the server. Data is turned into a container end voyage message to be forwarded to SICIS when the GPS-location sent is located inside the geo-fenced location of the receiving premises.

5.2.5 CSD data

GPS-locations from a CSD is given each 30 minutes. It does not help following each road a container took, but in general a route can be followed. The corners in the red line in the picture below show where a position was recorded.

5.2.6 Container Scanning

Container Scanning in YICT is done after the Consignor announced in time the scanning request on behalf of INTEGRITY. When the container enters the terminal, it is directed to the scanning equipment. After the scan the information a container scan was performed in YICT is stored in SICIS. An authorised user is able to view this information in SICIS by the “scan container event” stored in the container voyage:

Check Point															
★	<input type="checkbox"/>	Role	Role Category	Company Name	Actual Date	Actual Time	Event	Location	Port of Loading/Discharge	Port of Destination	Supplied By	Report Time	Seal No.	eSeal No.	Vessel Name
1	<input type="checkbox"/>	Forwarder	Destination	Allport Ltd											
2	<input type="checkbox"/>	Logistics service provider (import side)	Destination	BAP Logistics Ltd	12-08-2010	10:57	Container Opening / end Journey	BAP Warehouse			SICIS	12-08-2010 10:57			
3	<input type="checkbox"/>	Terminal operator	Destination	Felixstowe Dock and Railway Co.	11-08-2010	10:42	Gate Out	Felixstowe - Trinity			HDN	11-08-2010 10:08	NA		MSC MELATILDE
4	<input type="checkbox"/>	Terminal operator	Destination	Felixstowe Dock and Railway Co.	06-08-2010	00:16	Unloading	Felixstowe - Trinity			HDN	06-08-2010 00:08	null		MSC MELATILDE
5	<input type="checkbox"/>				05-08-2010	12:36	Actual Time Arrival	Felixstowe - Trinity			HDN	09-09-2010 08:08			MSC MELATILDE
6	<input type="checkbox"/>	Terminal operator	Origin	Yantian International Container Terminals	09-07-2010	18:54	Loading	Yantian International Container Terminal			HDN	09-07-2010 19:41	7058083		MSC MELATILDE
7	<input type="checkbox"/>	Terminal operator	Origin	Yantian International Container Terminals	06-07-2010	01:53	Scan	Yantian International Container Terminal			SICIS	08-07-2010 02:32			
8	<input type="checkbox"/>	Terminal operator	Origin	Yantian International Container Terminals	30-06-2010	07:28	Gate In	Yantian International Container Terminal			HDN	05-07-2010 11:36	7058083		MSC MELATILDE
9	<input type="checkbox"/>	Forwarder	Origin	Cargo Services Far East Limited	30-06-2010	07:03	Close Container, Initiate Tracking	CARGO SERVICE YANTIAN WAREHOUSE			SICIS	05-07-2010 11:27	7058083		

Fig. 32: Container voyage including a container scan in YICT

5.2.7 AIS Data in SICIS

AIS data is integrated into SICIS seamlessly. Since data belongs to one container there is no difference when displaying this. This could be seen in following Screenshot where received AIS-data from a container transporting vessel is shown as a red line on a global map. Since this line connects the single points where the vessels position is reported by AIS, it may be drawn over land and not in water but this is just an issue of infrequency of reports from AIS.



Fig. 33: Complete container voyage including recognition of waypoints

5.2.8 Consignment information

The consignment information can be given in two ways. The first way is by providing a document type and a reference number, see below. In order to keep the system open as far as possible, multiple numbers of the same document type for the same container can be stored, for example having more than one purchase order contained in one container.

Consignment Reference Number	Document Type	Reference Number	
	Advance Shipping Notification	ASN 0001	+
	Custom Declaration Document	CDD 0002	-
	House Bill of Lading	B/L 0003	-
	Line Bill of Lading	B/L 0004	-
	Packing List	PL 0005	-
	Purchase Order	PO 0006	-
	-- Please Select --		-

Fig. 34: Different possibilities to insert Consignment reference numbers

The second part realised in SICIS is the ability to upload real consignment information stored in a graphical format. Using the system a document with can be uploaded to SICIS, enabling other authorised partners to view this document. The accepted formats are pdf, gif and tif, in which the pdf file is the preferred one.

5.3 Events tracked in SICIS

Depending on the additional systems used, the additional container tracking done with SICIS can be shown with graphics below.

Manual start and end container journey only using the web-based SICIS

When using the SICIS functionality without terminals providing data input to HDN, two events should be inserted and stored in SICIS for each container voyage for tracking purposes. This case did not happen during demonstration. Yellow triangles mark events entered directly into SICIS.

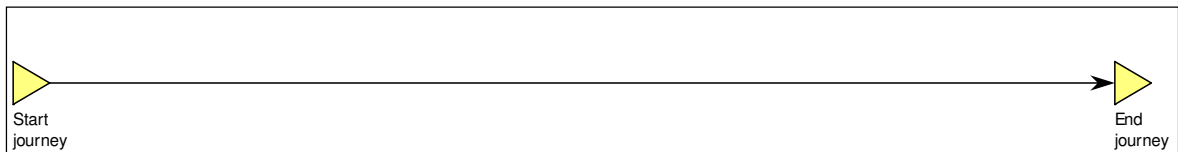

Fig. 35: Manual start and end container journey

Using the SICIS mobile interface

The mobile interface could be used as a standalone interface starting and ending containers in SICIS. This is shown with pink triangles below and is an alternative to start and end container voyages in SICIS. If a container is started using the web-based interface, it could be ended by the mobile interface and vice versa. Even if a container is started by a CSD and the device stops operation or is lost, the individual container voyage should be ended using one of the SICIS interfaces.

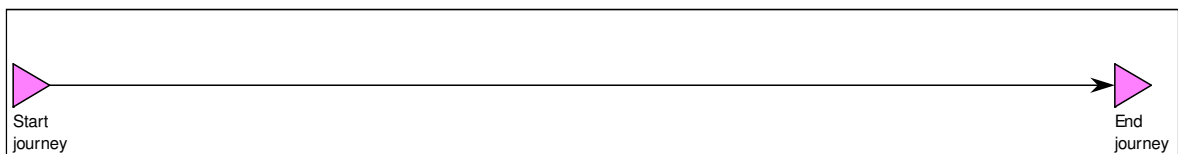

Fig. 36: Start and end container journey with mobile interface

Manual start and end container journey using Hutchison ports

When using basic SICIS functionality and terminals providing data input to HDN, more events are stored in SICIS for a container voyage. This is the case when tracking is done by the software only. Green triangles mark events data received by SICIS from HDN.

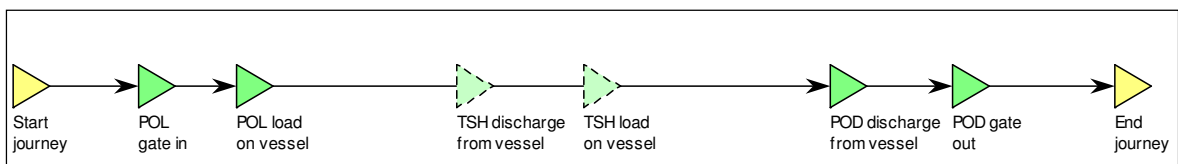

Fig. 37: Manual start and end container journey using Hutchison ports

Using a SAVI CSD only

Using a SAVI CSD without terminals providing data input to HDN, following line of events is stored in SICIS. This did not happen during demonstration. Blue triangles mark events data received by SAVITrak. The heartbeats line indicates constant information flow (each 4 hours in good conditions).

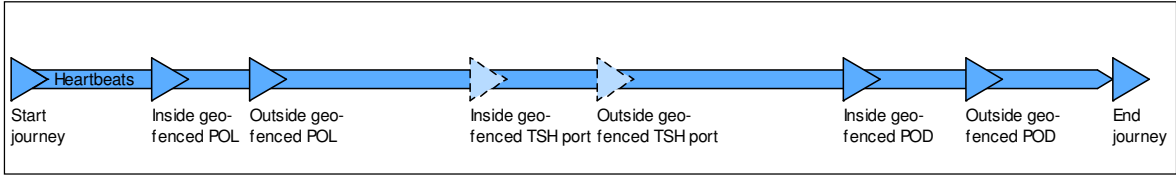

Fig. 38: Using a SAVI CSD only

Using a SAVI CSD and Hutchison ports

Using a SAVI CSD and port terminals with data input to HDN, following line of events is stored in SICIS. This is seen as the standard case. In order to simplify the diagram, the names of events are reduced, but have the same saying than noted in the above shown diagrams.

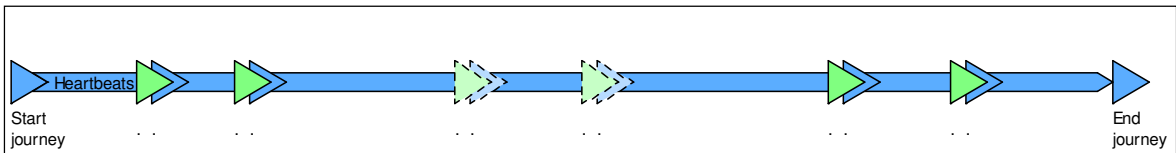

Fig. 39: Using a SAVI CSD and Hutchison ports

Using a SAVI CSD, Hutchison ports and AIS data

In the later stages of demonstration after AIS-data was successfully implemented and vessel positions gained were combined with container loaded on respective vessels the diagram of the previous chapter was extended by a continuous data flow from load on vessel until discharge from vessel shown in orange below. A transhipment is not shown, as long as a container not onboard a vessel, an AIS-information is not given.

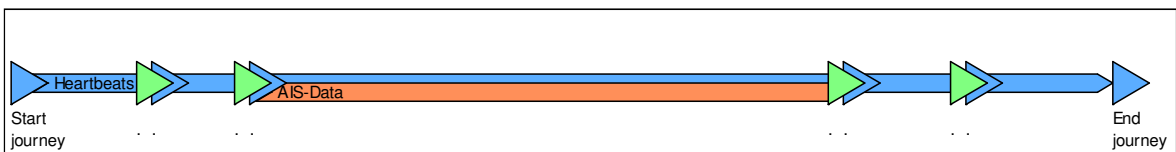

Fig. 40: Using a SAVI CSD, Hutchison ports and AIS data

Manual container events , Hutchison ports and AIS

From all given sources of information, an arbitrarily permutation of sources may feed for each one container voyage, even non-Hutchison terminals were used, multiple CSDs may be attached to one container and start container voyage and end container voyage are not expected from the same system. Multiple CSDs might be used in order if devices are unable to connect via GSM in parts of the world. Since each CSD still has a low probability of failure the constant flow of information may fail at any one time during the

voyage. On the other hand CSDs might be stolen but the container is left intact because of industrial espionage or usable parts of the CSD (e.g. the GPS-receiver or the rechargeable battery).

Using country-based CSDs, Hutchison ports and AIS

Another possibility is the use of seals per country – for example when using Customs seals in a country like China or inside the EU. In this case one seal is attached to the container at the factory and removed in the port of loading. Another seal is attached in the port of discharge and removed at the first consignee. A picture might look as follows regarding inclusion of AIS data:

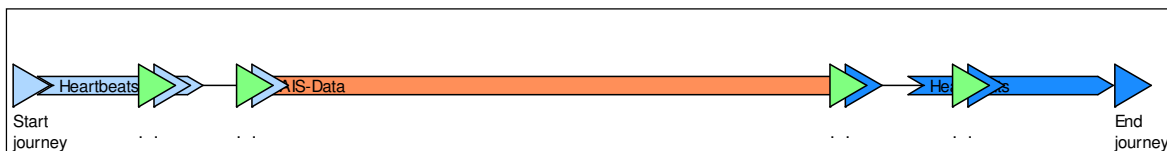

Fig. 41: Using country-based CSDs, Hutchison ports and AIS

Since permutation can be great, we abandon the idea to have one picture covering all data sources – during a container voyage.

5.4 Demonstration Results

This part describes the results of demonstration and gives some insights into data handling and processing and gives background information which a typical user of SICIS does not have.

In general the use of the whole system was an advantage for all participants according to their own statements. The case of a container appearing unexpectedly at the consignee still happens today. With system like SICIS such occurrences are reduced and reliable information can be obtained by a tradelane partner himself without questioning other companies involved in container transport. All parts of the system named worked reliably and efficiently together, even small drawbacks did not endanger the system or upset the users of the system.

5.4.1 Data availability in SICIS

Data availability in SICIS is strongly dependant on the attached systems. This issue is discussed in two parts in this chapter: the first part contains the fixed installations in terminals where data is forwarded using wires or optical fibre, the second part covers data gained and forwarded by mobile devices, the CSDs and their respective systems.

Access to SICIS and data forwarding is highly dependent on the availability of further systems like the internet, power supplies and working hardware including backup systems. These issues are not covered in this report since a failure of such infrastructure could be named general public risks which are not part of INTEGRITY investigation.

5.4.1.1 Basic data sets by manual data input

A container voyage stored in SICIS has at least two events stored if users work according to the plan: a start container voyage and an end container voyage. This data is the minimum of data records if no HDN-equipped terminal is used for the container voyage. Tradelane partners in INTEGRITY are chosen in order to use HDN-equipped terminals, therefore this case did not happen.

5.4.1.2 Events including Hutchison Data Network (HDN)

When a container is known to SICIS, a software mechanism called watchdog is used to detect container events available on HDN. This includes gate in, gate out, load on vessel and discharge from vessel – messages from all Hutchison terminals worldwide. These events are detected by the watchlist and inserted in SICIS giving a user the access to these events.

If a container is loaded on a vessel in Hong Kong, Terminal 9, and is unloaded at ECT in Rotterdam, with a respective road gate in and road gate out this information adds to the voyage start end information, thus making up at least 6 events. If a transshipment is done in a HDN-equipped terminal, these two extra messages per transshipment (discharge from vessel, load on vessel) are stored in SICIS as well, giving more information because a transshipment is usually not forwarded to a receiver of a container or Customs authorities of the receiving country.

5.4.1.3 Data gained by use of CSDs

The SAVI CSDs for the demonstration were set up with a 30 minutes wakeup in order to gain a GPS position if possible and every 4 hours to send all information gained to the SAVI server. This configuration enables a container voyage of minimum 6 weeks with a fully charged battery and a narrow distance between single positions. If the fastest transport mode is done at 100km/h, GPS-positions gained every 30 minutes are 50 km apart. This information was seen by tradelane partners as a sufficient.

The data gained by CSDs add to existing events for each container in SICIS. When a CSD is attached the manual data input for Stat and End journey is not required.

Start Container Journey

Using a CSD to start a container replaces the need for a manual start journey event using SICIS. The CSDD event in SICIS is enhanced in terms of security since the position and the time is gained from GPS-signals instead from a person inserting data manually.

Road transport

During road transport the conditions for a CSD to gain data needed is generally better than during other transport modes: On a truck container doors are 'open to the sky' giving constant GPS-data reception. Main roads are often completely covered by GSM-posts giving continuous communications coverage.

Rail transport

There were no containers transported by rail during INTEGRITY. This was not intentional but happened by the nature of demonstration containers. Data availability from rail

transport are probably similar to road transport since containers on a rail car are similar to containers on a truck chassis.

On some occasions containers on a rail car might be placed doors facing each other in order to raise hurdles to open doors during rail transport. If this is the case for individual transports the information gained from CSDs is probably lower than using road transport.

Terminal storage

Inside a terminal or fenced yard which is not the location for a start or end container journey (e.g. a transshipment terminal), a container are stored in stacks up to 5 high. Depending on the actual position (top of stack and CSD facing open sky in contrast to lowest position in the centre of a stack) The location niformation will be of variable quality but, generally, communications will be maintained.

Vessel transport

Data from a CSD can be delayed by days or weeks depending on the position of the container on a container vessel: if it is stored below hatch covers it was found that no signals could be received at all until the hatches were removed in europe or a transshipment port.

The sender or receiver of a container is not able to give an order to place a container on deck to allow receiving of a GPS signal and get contact to a cell phone network at all times.

If transhipments are performed but not announced when the container is unloaded and stored on the quay and it is able to acquire the current GPS-location and sent a heartbeat message via GPRS.

When a container is stored on deck the situation is different. If stored with visibility to the open sky, GPS signals can be obtained at each wakeup of the CSD but when the ship is out of 'mobile phone range, no communications are possible. In this situation the CSD will continue to collect GPSS locations but will store them for transmission when communications are next established.

Authorities Check on site

An authorities container internal check inside a terminal at the Customs check area was performed during demonstration.

Authorities Check on road

An authorities container internal check outside a terminal on roads not performed during INTEGRITY demonstration.

End Container Journey

The end journey event sent from SaviTrak™ was a door open alert combined with a geofenced area of the destination site. Data was obtained mostly reliable, but depending on the construction of warehouses and existing working processes, the data was sometimes missed due to metal roofing overlapping the external unloading bays.. The preferred process for an end journey event – dismounting a device, exposing to the sky for 10 minutes and subsequent deactivating – does not really fit into existing processes of drivers. They approach the unloading bay at the warehouse backwards, then container

doors are opened (often beneath a roof) and the container is further backed to the bay until contact. The driver then enters the warehouse and exchanges information and observes the unloading.

To overcome this the CSD is removed from the container and carried outside to get as clear view of the sky. It will then send the door Open/End journey message to the systems. If however it is placed close to the perimeter fence of the site it may pick up a location outside the geo fenced area resulting in a 'door Open, without an End Journey.

5.4.2 Conclusion of CHINOS tests

The CHINOS system has been developed within the CHINOS project and is able to readout data from RFID eSeals and container tags and to forward the respective information to SICIS. To prove the functionality of the system and the interface to SICIS, several containers were equipped with eSeals and container tags in Hong Kong and scanned at several locations throughout their voyage to Europe.

It has been shown that the CHINOS system is able to create different kind of events which could be used as source for SICIS in order to generate events which increases the visibility of the supply chain. Especially, the usage of the handheld reader enables the user to generate events at different locations easily. However, the CHINOS system is also able to use fixed mounted readers in order to automate this process, for example during the project CHINOS a fixed mounted reader at the train gate has been used.

It has been also demonstrated that the CHINOS system is able to detect an unauthorized opening event which improves the security of the supply chain.

The CHINOS system is able to fill the gap between the cheap bolt seals which offers no additional data and the more expensive CSDs which are offering the best data quality. It depends on the business case and the requirement of the user which kind of seal and device he would like to use.



Fig. 42: Reading of container RFID tag and eSeal data using the CHINOS handheld RFID reader

5.5 Lessons learned during INTEGRITY demonstration

This section gives some information about what was learned by the whole team during demonstration. Reflections on expectations and drawbacks during execution are stated here.

5.5.1 The fallback solution

The idea to use Container Security Devices or eSeals as the single source for container transport visibility was not acceptable to INTEGRITY Partners.

The demonstration itself showed that a fallback solution using terminal information only is a big advantage against competing systems not offering such a feature. Basically two fallback solutions were created: The first one is a manual data input in order to feed the system with basic data and the other was a small part of the application enabling users with advanced mobile phones (e.g. iPhone 4th generation) to enter start and end container events and retrieve relevant data.

The fallback solution could be used when following circumstances occur:

Lack of hardware (devices, handhelds, computers nearby)

Depending of the organisation of an individual company and internal information forwarding, a lack of hardware may occur anytime for many different reasons. When hardware to track containers is unusable or unavailable the container movement cannot be delayed. Reasons for this might be slots already booked in deep sea carrier and rail transport or trucks ready for departure or time-critical cargo. INTEGRITY Demonstration showed any delay to a container departure is unacceptable.

One-off shipments

Commercial arrangements in China often lead to ‘one off’ shipments e.g. a company will enter into a contract to supply but then sub contract the actual manufacturing etc. to a number of other companies. As result containers for the shipment originate in a number of locations which may not be used again or weeks or months. The costs of arranging for CSD’s to be attached at these diverse locations plus the work in setting up their geo fenced locations could not be justified.

The SICIS facilities to perform a manual Start Journey enabled basic tracking of the container to be performed.

5.5.2 Cell phone use

Demonstration showed the need for an access to SICIS when not having a computer ready for use. The use of a cell phone capable of running an internet-browser to start and complete container voyages is a good demonstrator to combine new emerging technologies with day-to-day equipment. The use of a handheld is always something new, but using an own device where the software looks exactly the same as using a computer enhances the acceptance of the rollout new technology. In addition advantages using software from one (worldwide) centralised server enhances the maintainability and serviceability of the software project.

5.5.3 Data gained from one terminal provider only

This demonstration phase had one Terminal operator in the Integrity Partners so certain data (terminal gate in and out, load on/discharge from vessel) was only available from this terminal operator.

However if a tracked container is transhipped at a terminal outside the control of these operators then no unload or load messages are received. This lack of data might lead to a wrong analysis of the actual situation.

During the demonstration additional tradelanes were facilitated giving INTEGRITY the chance to receive data from another terminal operator than run by HPH, namely DP World. Collaboration between these two terminal operators was successful.

5.5.4 Manual data input versus automatically gained data

Data input directly into SICIS does not rely on other systems apart from the internet and SICIS itself. However, if a worker inputs data of a whole shift at the end of the shift, exact times, when a container left a terminal could be an estimate, and not exact local time.

If data is acquired automatically from a system where the worker is recording the details as the actually event takes place e.g. ingate, the quality of the data will be higher.

5.5.5 Satellite vs. terrestrial AIS vessel tracking data

The original intention in the Integrity project was to use satellite based AIS data to track the location of ships carrying containers on SICIS. The interface was developed and initial testing conducting but it was found that due to the limited number of satellites and a number of technical issues with the satellites systems, data could only be received from one satellite and this did not actually cover an area transited by vessels on the Far East/Europe trade. A solution to these problems was sought and terrestrial AIS data providers were contacted to provide an alternative data source. Integrity partner OHB reached an agreement with a provider of terrestrial AIS data to provide data.

The terrestrial data covers the Mediterranean Sea and the area around to northern Europe and, in late March 2011, the first vessels with SICIS containers entered this area. Initial results have shown that there are some 'holes' in coverage, generally in the Ionian Sea, north of Tunisia/Algeria, off the SW tip of Portugal and across the Bay of Biscay but, outside these areas the results have been very excellent.

It is now planned to use existing functionality in SICIS to set 'geo fences' around specific maritime areas e.g. Gibraltar Straights, Brest and the Dover Straights, to see if these locations can be 'trapped' and reported to SICIS users.

6 Modelling the SICIS benefits

In this section, we describe the basic set-up of the benefits model and introduce the basic relevant concepts.

The trade lane can be described in terms of *business processes* and *roles* of organizations involved. Business processes can be detailed out in terms of a *workflow* incorporating *information processing steps* and *information flows*. The scope of the trade lane in the case of full container loads (FCL) extends from loading the container (“stuffing”) to unloading the container (“stripping”). In the case of less than container loads (LCL), the scope of the trade lane is set in a similar fashion on the level of individual shipments.

The workflow usually consists of a normal flow of activities and alternative flows of activities which are triggered by an event, in some cases a disruption. Descriptions of such flows of activities are given in use case descriptions.

An information flow is characterized by the source and destination of the flow, and its content, given by data elements. The *quality* of the information flows is defined in terms of information quality dimensions such as completeness, accuracy, and timeliness. The information flows and their quality can be expressed in a diagram; see Fig. 43. Information processing capabilities are expressed in terms of production of information: capture, storage, transform, and communicate. These capabilities appear as *features* of an information system.

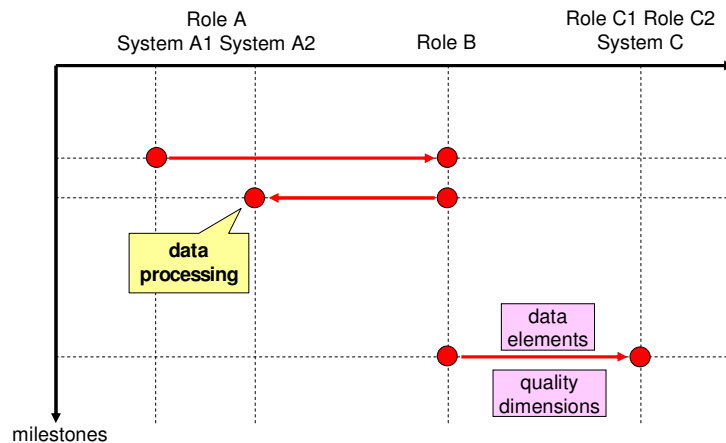

Fig. 43: Information flows

Fig. 43 indicates that an organizational role (A) can be represented by different information systems (A1 and A2) that are nodes in the information network, or that a single (inter-organizational) system (C) represent different organizational roles (C1 and C2). Information flows occur at discrete points in time. We restrict ourselves to those points in time relevant to the workflow in the trade lane, i.e. so-called milestones (or checkpoints). Observe that information about events in between milestones can be used to predict milestone events.

For each trade lane, a *base line scenario* will be defined in terms of information system features. The base line scenario will correspond with the offset situation, i.e. before the introduction of the SICIS system. In addition, *advanced scenarios* will be defined with advanced features that provide progressive quality levels of information flows and enhanced information processing capabilities. The advanced features support *monitor and control loops* that enable enhanced performance.

In this manner, the benefits of a (combination of) SICIS features then emerge as the performance improvements, i.e., the difference in performance between the base line scenario (without the features) and the advanced scenario (with the features). Performance is measured in terms of *key performance indicators* that have been established in the trade lane. The performance related to a scenario is analyzed using the framework of the monitor and control loops in the trade lane, to be discussed in the next section.

6.1 Monitor and Control Loops

In this section, we discuss the structure of monitor and control loops. We shall motivate the deployment of monitor and control loops in the following sections.

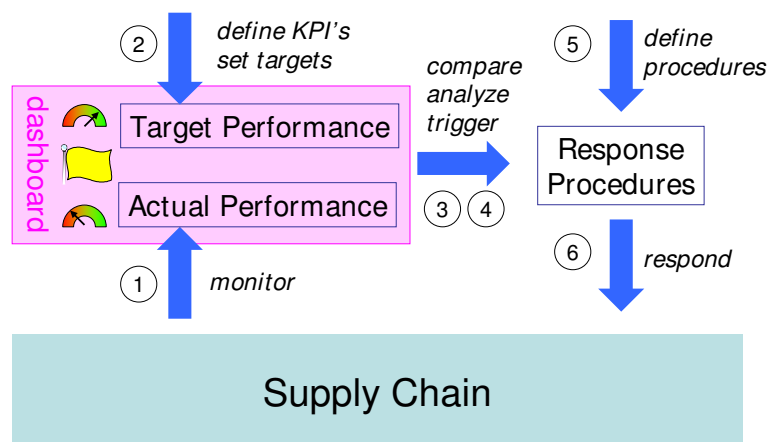

Fig. 44: Monitor and control loop

A control loop is structured as in Fig. 44. It requires the following six generic features.

1. *Capture and storage of actual data from the supply chain*

Such actual data can be captured using devices attached to the container or at the milestone facility. In addition, actual data can be retrieved from legacy systems. In principle, data capture should be immediate, but reporting can be done based on requirements of the decision maker.

2. Capture and storage of target data

Target data can either be planning data, which needs to be retrieved from a legacy planning system, or performance targets, which needs to be retrieved from a variety of sources, including planning system, customer relationship management system, etc.

3. Processing of data by which actual and target data are analyzed and compared

Processing of data may involve statistical analyses, forecasting, and other business intelligence techniques. It may also involve the use of thresholds beyond which a difference between actual and target performance induces a trigger.

4. Communicating a trigger when induced

When a trigger has been induced, the trigger may be sent to another system that executes a response procedure.

5. Storage of response procedures

Usually, triggers are used to alert events for which response procedures are in place and that have been defined.

6. Processing a trigger which induces a response procedure

Upon reception of the trigger, the response procedure needs to be activated and customized to the parameters given.

The control loop framework clarifies that combinations of features are required to enable a monitor and control loop. Not all features need to be provided by SICIS. We give two examples.

Example 1: “Replan dock reservation at consignee warehouse upon container delay.”

A maritime container has been delayed at the terminal. At the milestone “container dispatched from terminal”, the actual time (1) is compared with the planned or target time (2). The delay is determined, and when it exceeds a certain threshold (3), a trigger is induced (4) which updates the expected time of arrival in the system of the consignee, i.e. at the milestone “container arrived at warehouse”. A re-planning procedure has been defined upon reception of an estimated arrival time update (5). Based on the updated estimated arrival time, the dock planning system at the consignee reserves a new slot for the truck (6).

The required features of SICIS and other information systems are the following:

SICIS: capture the target time of a specific container at a specific milestone

SICIS: capture the actual time of a specific container at a specific milestone

SICIS: compare actual and target time, determine the delay and analyze whether a threshold has been exceeded

SICIS: communicate a trigger when threshold is exceeded to planning system PLAN of consignee

PLAN: upon reception of the trigger, activate the replanning procedure

PLAN: re-plan the reservation of a dock for the truck which carries the container

Example 2: “Prevent Customs delay of container at port of loading through pre-arrival clearance.”

Customs at the port of arrival capture –48 hours in advance of the milestone “ship arrival”– the actual data elements available from Customs declaration of a container (1) and compare those with the required data elements for pre-arrival clearance (2). A deviation is observed (3) due to inferior data quality of certain required elements (e.g. missing or inconsistent). A trigger is induced which

puts the container status to “red” at the milestone “ship arrival” in the WARN system at Customs at the port of arrival. The WARN system has a number of response procedures in place to deal with deviations (4). In this case, the WARN system sends out a report to the shipper with the updated flag status and the request to improve the quality of data 24 hours in advance of the milestone “ship arrival”. The monitor and control loop is repeated 24 hours in advance of the milestone “ship arrival” and the container status may be updated to “yellow” or “green” depending on the data quality of the declaration.

The required features of SICIS and other information systems are the following:

SICIS: capture the target data quality of elements of a Customs declaration of a container

SICIS: capture the actual data elements of a Customs declaration of a specific container in advance of a specific milestone

SICIS: compare actual and target data quality, determine the deviation in data quality, and analyze whether a threshold has been exceeded

SICIS: communicate a trigger when threshold is exceeded to system CUSTOMS of Customs at port of arrival

WARN: upon reception of the trigger, activate the appropriate response procedure

WARN: when applicable, update the status flag of the container at the milestone “ship arrival”

WARN: when applicable, send a flag status update report

WARN: when applicable, send a request to improve the data quality of the declaration

In Fig. 44, the *dashboard* refers to the user interface component of the decision support system that visualizes the actual and target performance of the supply chain to the extent it requires the attention of the decision maker. It may also suggest how response procedures will correct, prevent, or resolve performance deviations.

Strategic response procedures are based on past performance and will require extensive analysis, as they will aim at redesigning business processes in such a way that deviations will be resolved. We do not consider such long term responses in detail in this deliverable.

Tactical response procedures will also be based on the analysis of past performance and will be triggered by recurring deviations. The response will aim to prevent future deviations and will involve coordination in the supply chain.

Operational response procedures are usually triggered by deviations of execution performance relative to target or planned performance. The effect of these responses will be corrective.

The actual performance of the supply chain achieved after one or multiple cycles in the monitor and control loop indicates the level of performance obtained by this mechanism.

In addition to the availability of the required features, the effectiveness of the monitor and control loop is determined by the extent to which the supply chain can be observed, and the extent to which the response procedures are able to control the performance of the supply chain. The ability of control may be hindered for example by the fact that the container is in a remote area and can only be reached after some time, or that certain required resources are not available.

We may indicate the types of benefits that can be achieved with these control loops.

The benefits of Example 1 are induced by synchronizing truck arrival and dock availability, which can be expressed in terms of improved utilization of dock capacity, reduced waiting times of trucks at the warehouse, etc. The benefits of the monitor and control loop are limited by e.g. the uncertainty in travel times of the trucks between milestones.

The benefits of Example 2 relate to the possible prevention of a yellow or red flag status by the timely provision of complete and accurate data, and can be expressed in terms of reduced throughput times, timely delivery, less uncertainty in throughput times, etc.

In the following sections, we discuss some important aspects of the monitor and control loops in more detail.

6.2 Quality of information: Visibility

We shall elaborate on the notion of visibility, which enables decision-makers in the supply chain to obtain the information they need to support supply chain goals, in terms of information quality. We discuss quality of data, following Strong et al. (1997). In this section, we will use the term data instead of information, as in rigorous discussions on the topic, information is already assumed to constitute of data that is fit for use by data consumers. Fitness for use means that the data should be accessible to the user, the user should be able to interpret the data, and the data should be relevant to the user. In particular, it should be offered to the decision-maker in a timely fashion, and the data should be accurate. Strong et al. (1997) emphasize that data quality is not merely an intrinsic property.

Tab. 4 provides a number of categories of data quality. We illustrate these categories and dimensions in the context of container transport. Intrinsic dimensions of data quality basically refer to the correspondence with reality. In planning, this may refer to the fact whether the receiving party believes that execution will be done according to the planning. In execution, the question may be whether received data reflects the actual status. In field operations, accessibility of data certainly is an issue. Decision-makers in the field need to be informed about disruptions, for example, the delay of a transport mode and resulting re-planning activities in a timely fashion, so that waiting times and low utilization can be avoided. In some cases, data security is required in order to establish supply chain safety and security. An important criterion to justify investments in an inter-organizational system such as SICIS is the question of relevancy, in particular the value added, of data provided, given its accuracy, accessibility, and timeliness. Both for planning and execution purposes, data need to be represented in such a way that the decision-makers have an immediate understanding of the data presented to them. This may require that, for example, expected arrivals of trucks at the terminal are matched with capacity planning data of straddle carriers and release orders of containers that need to be picked up.

Data Quality category	Data Quality dimensions
Intrinsic	Accuracy, Objectivity, Believability, Reputation
Accessibility	Accessibility, Access security
Contextual	Relevancy, Value-Added, Timeliness, Completeness, Amount of data
Representational	Interpretability, Ease of understanding, Concise representation, Consistent representation

Tab. 4: Categories and dimensions of data quality (Strong et al. (1997)).

Timeliness of data is especially important in the case when data values change in time; e.g. the final destination of a container may change when ownership of the cargo changes during transport. An important lever in this respect is the use of original data sources as much as possible. Accessibility and timeliness of data ensure that authorized users have access to up-to-date information when required. Organizations in global supply chains are dependent on the capability of others to deliver reliable data in a timely way. As is apparent from the examples given above, the data quality categories may be required simultaneously.

6.3 Performance indicators

Supply chain performance indicators help identify the gap between targets and the actual process outcome(s) and henceforth support monitor and control loops. Targets that appear in container transport are, amongst other things, expressed in terms of efficiency, time compression, flexibility, resource utilization, and security. The performance of container transport and the supply chain in general is not the concern of a single organization and is not one-dimensional. Indeed, system improvements involve multiple supply chain performance indicators so that relevant trade-offs need to be made; e.g. between costs and fast delivery. Furthermore, performance does not only involve the logistics performance of the network in terms of economics, but also in terms of environmental impacts, and security and safety. In this manner, we consider the performance dimensions of container transport in terms of people, profit, and planet.

Besides the various dimensions of performance that can be discerned, one may observe that the involvement of multiple stakeholders also affects the way that performance can be monitored and controlled. In particular, we consider the issue of firm-specific versus supply chain wide performance indicators.

A number of different frameworks to evaluate and measure performance in logistic processes have been developed. Traditional frameworks include four types of indicators: quality, time, cost, and flexibility; see for example (Neely et al. (1995)). Organizations involved in container transport are progressively concerned with performance of the supply chain as a whole, and with respect to environmental and social impacts of transport. Important examples of environmental and social performance measures are emissions, noise levels in populated areas, and safety and security of cargo and containers. We will discuss a number of frameworks below.

Traditional performance indicators are a necessary tool to evaluate organizational performance, but they are too specific and hence not always useful to measure inter-organizational performance or supply chain performance. According to Beamon (1999), three different types of indicators are necessary to measure supply chain performance, namely resources (measuring cost and efficiency), output (measuring customer service) and flexibility (measuring changes and disruption handling); see Tab. 5.

Type of indicator	Examples
Resource indicators	total cost; distribution cost; information carrying cost; transportation cost; storage cost; material cost; labor cost; capital productivity; labor productivity; capacity utilization; return on inventory
Output indicators	delivery lead time; cycle time; throughput time; number of errors made; customer complaints; customer response time; waiting time; average lateness of shipments; average earliness of shipments; percent on time deliveries; customer satisfaction
Flexibility indicators	number of changes in the process; number of disruptions; time spent on disruption handling; impact of disruptions

Tab. 5: Types of indicators and examples (Beamon (1999))

The performance indicators consist of a number of categories. The cost-based indicators and the indicators based on capacity, productivity, and utilization, are resource indicators. The time-based indicators are output indicators, The disruption-based indicators are flexibility indicators. The security-based indicators are best classified as flexibility indicators.

A framework which takes strategic goals as a starting point is the balance score card (Kaplan and Norton (1992)), which is based on the viewpoint that a performance measurement system should give managers adequate information to answer four questions; see the leftmost column of Tab. 6.

Brewer and Speh (2000) adjusted the balance score card to evaluate supply chain performance, by founding this performance measurement system on the principle that it should give organizations in the supply chain adequate information to the four balance score card questions. They attached supply chain goals and supply chain performance indicators to the four questions. See Tab. 6 for the relation between the original balance score card and the supply chain approach to the balance score card.

In line with the balance score card, performance measures of transport logistics should not only focus on operational performance. Using the Supply Chain Operations Reference (SCOR) model as a reference, Lai et al. (2002) identify three dimensions of supply chain performance in transport logistics, namely service effectiveness for shippers, operational efficiency for transport logistics service providers, and service effectiveness for consignees.

Balance score card questions	Supply chain performance (Brewer and Speh (2000))	
	Goals	Possible indicators
Internal business perspective: What must we excel at?	Waste reduction Time compression Flexible response Unit cost reduction	Supply chain cost of ownership Supply chain cycle efficiency Average response time % of supply chain target cost achieved

Innovation and learning perspective: How can we continue to improve and create value?	Product/process innovation Partnership management Information flows Threats/substitutes	Product finalization point Product category commitment ratio Number of shared data sets Performance of competing chains
Customer perspective: How do our customers see us?	Improved product/service quality Improved timeliness Improved flexibility Improved value	Number of customer contact points Relative customer order response time Customer perspective of flexible response Customer value ratio
Financial perspective: How do we look to our shareholders?	Higher profit margins Improved cash flow Revenue growth High return on assets	Profit margin by supply chain partner Cash-to-cash cycle Customer growth and profitability Return on supply chain assets

Tab. 6: Balance score card questions, goals, and performance indicators (Kaplan and Norton (1992)).

6.4 Identification and quantification of benefits

In the literature, it has been pointed out that lessons can be learnt from the quality movement in order to reap the collateral benefits of security investments (Christopher and Lee (2004); Lee and Wolfe (2003); Lee and Wang (2005)).

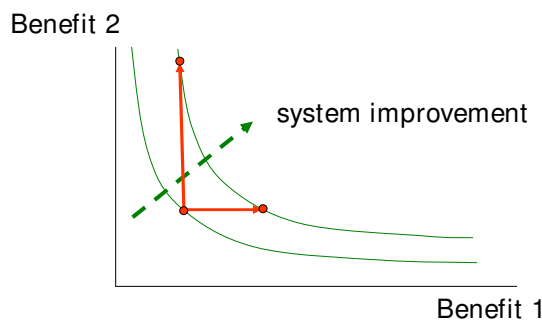

Fig. 45: System improvement and trade-offs between benefits

The collateral benefits of security investments have been detailed out in (Rice and Spayd (2005)). Such collateral benefits can be understood as trade-offs between different performance dimensions under system improvement, as depicted in Fig. 45 (Lee and Whang (2005)). In this section, we describe by means of which methods one can identify and quantify benefits of monitor and control loops. First observation is that benefits of the SICIS system can be described at a number of levels. Not all these levels of benefits require an extensive analysis involving monitor and control loops.

Benefits Level	Brief Benefits Description
1. Improved quality of information	The provision of information is more timely, accurate, complete, etc.
2. Administrative benefits	Computer support in handling information resulting in shorter process times and fewer errors.
3. Trade lane and governance benefits	<p>Higher logistics reliability</p> <ul style="list-style-type: none"> - Enhanced information on milestones and forecasts - Slack time and delay reduction - Enhanced disruption management - Green lane & reduced checks <p>Reduction of logistics costs</p> <ul style="list-style-type: none"> - Pipeline Stock reduction - Reduced obsolescence and markdown costs - Reduction of demurrage and retention costs - Reduction degassing costs <p>Increase cargo quality</p> <p>Enhanced risk management</p>

Tab. 7: Three levels of (potential) benefits

First level benefits are expressed in the quality of information as such. The benefits express that information is available to the decision maker without exploring what benefits can be obtained by using the information. An example of such a benefit is: “The logistics planner receives an alert when a container arrival has not been confirmed in time.”

Second level benefits are defined in terms of more efficient administrative processes. The relevant system features support the retrieval, storage, communication, and transformation of information, in short the production of information. An example benefit reads: “The planning system receives electronic alerts that can be interpreted without human interference, which allows the system to immediately report a planning update to the human decision maker. This reduces the handling time and costs of processing these alerts.”

Third level benefits express the impact of enhanced information provision in terms of performance improvements. The analysis of such benefits requires the analysis of monitor and control loops as discussed before.

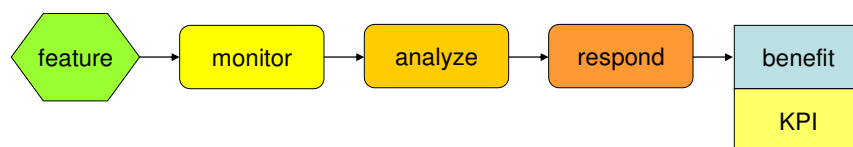

Fig. 46: Structure of the benefits analysis.

At the left hand side of Fig. 46, the features of the supporting information systems are given, including the capture, storage, processing, transfer, and security of data. These features support the monitoring, analysis, and response activities in the control loops. The

enhanced performance levels that can be attributed to the control loops are identified as benefits, expressed in terms of Key Performance Indicators (KPIs).

6.4.1 First level benefits

The first level benefits are directly inferred from the information services provided. Enhanced visibility refers to the improved quality of information in terms of the quality dimensions; see Tab. 7. Another important first level benefit is reduced uncertainty. Uncertainty will be expressed in terms of the error term of a standard forecast model, based on available historical data. Relevant parameters that will be forecasted are ETA, ETD at designated milestones in the trade lanes, etc. The amount of uncertainty will decrease as the time of the forecast (update) approaches the event itself. The timing of the decision which uses the forecast is therefore very relevant. We define the time difference between the forecasted event and the time of the forecast as the time horizon of the forecast.

The data quality dimensions are used to define the target performance of the information system features, and as such they are the target values of the non-functional requirements.

6.4.2 Second level benefits

The second level benefits involve the impacts of the system features on the administrative processes, predominantly in terms of reduction of costs and errors. We propose the use of the Time driven ABC (Activity Based Costing) as a costing method, as it requires estimates of only two parameters; namely the unit cost of supplying capacity, and the time required to perform a transaction or an activity (Kaplan and Anderson (2007)). In addition, the assessment of error rates could be modeled similarly, e.g. through the unit error rate of supplying capacity.

It will be necessary to distinguish the normal and alternate use cases. In particular, the costs of responses of disruptions could be considered using this method.

6.4.3 Third level benefits

Third level benefits require the use of information in monitor and control loops and reflect performance improvements of the supply chain system itself.

- Safety stock reduction

Safety stock reduction enabled by reduction of uncertainty, i.e. by better forecasts, reduced lead time, and reduced inspection rates, as described in (Lee et al. (1997)).

- Slack time reduction

A probability distribution of time between two milestones in container transport may help to quantify “slack” times that are used to hedge for uncertainty, as depicted in Fig. 47.

time between milestones distribution

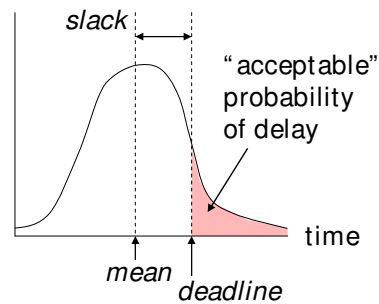

Fig. 47: Definition of slack time based on probability distribution and tolerance.

In this figure, we have used the mean of the distribution as a reference point. Another possible reference point is the total nominal processing time required to perform the tasks between two milestones. Usually, this would give an overestimate of the available slack, but may help to appreciate the need to reduce the present slack times.

The information services that constitute reduced slack time are similar to the ones required to arrive at reduced safety stock.

- Disruption correction, prevention, and resolution

With regard to disruptions, we consider the number (and percentage) of disruption which have been successfully corrected, prevented, or even resolved. In order to arrive at a benefits analysis of these measures, we consider the probability and impact of the disruption, i.e. the vulnerability of the supply chain with respect to the disruption. The analysis of (potential) failure modes, i.e. contingencies that disrupt processes in the trade lane, their probability of occurrence and their impact is also referred to as FMEA (Failure Mode and Effect Analysis).

The correction of a disruption requires the detection of it and a corrective action, based on a stored response procedure. The prevention or resolution of a disruption requires re-planning of supply chain activities or redesign of supply chain processes, based on analyses of stored supply chain data. In particular, the prevention and resolution of disruptions requires reliable forecasts of future status in the supply chain in order to anticipate disruptions.

- Risk management and risk reduction

Risk assessment involves the identification of its causes, the determination of the likelihood of risk occurrence, and the analysis of the impacts of an occurrence. The definition of monitor and control loops presumes the identification and recognition of failure modes, and the definition of proper measures that correspond to alternate scenarios. In such a manner, the definition of monitor and control loops constitutes part of the risk management procedure. Note that the extent to which disruptions are corrected, prevented, or resolved is already covered by previously mentioned performance measures. The benefit of managed risk will be expressed in terms of the measures taken to do just that, i.e. the extent to which measures have been put in place to deal with uncertainty or disruptions. The benefit of reduced risk should indicate the extent to which

the vulnerability has been reduced, i.e., to which extent the probability and impact of disruptions has been reduced.

6.4.4 Derived benefits

Enhanced safety and security can be established in several ways. The correction, prevention and resolution of disruptions mitigate the impact of disruptions, reduce the probability of its occurrence, or even remove its causes. As a consequence, the supply chain is made less vulnerable and the associated risks are managed and even reduced. Enhanced safety and security can be measured in terms of the relative number of disruptions that have been corrected, prevented, or resolved. Moreover, the probability and impact of disruptions, indicating the vulnerability of the supply chain, can be taken into account. The number of safety and security measures in place can be used to assess the level of resilience.

Enhanced legitimacy comes down to the ability to comply with safety, security, and environmental regulations against lower costs and time. This enhancement is enabled by the availability of required data, i.e. visibility, and the ability to respond to disruptions and as such is based on an enhanced level of safety, security, and environmental awareness.

Reduced external interventions (inspections) is measured in terms of intervention (inspection) rates, while taking into account the time and costs of these interventions.

The visibility of and reduced environmental impacts is based on the level of visibility concerning environmental impacts and the reduction of environmental impacts can be measured in terms of environmental performance measures, such as carbon footprint.

Reduced shrinkage, lower claims and insurance costs, better brand image are to a large extent related to product value (at risk). The number of incidents in which products are compromised in container transport is relatively low, so improved security levels may have a marginal effect. However, the impacts via reduced chain inventory and reduced slack time may have a large impact on the insurance costs via the resulting lower value of chain inventory.

Better logistics performance, in terms of less logistics errors, higher productivity, better utilization of resources, and less waiting times. Logistics errors are caused by discrepancies between reported planned and actual status, where the discrepancy is caused by data transfer errors or a true disruption, such as inventory shrinkage or time delay, or a combination of both (Lee and Özer (2007)). As a consequence, logistics decisions are based on inaccurate data that affect the size and timing of inventory replenishments, planned pick-up or delivery time, etc.

Less logistics costs are incurred when fewer errors are made in the administrative and logistics processes, when logistics resources are utilized better and are more productive, and when safety stock and slack times are reduced.

Higher logistics reliability is based on less logistics errors, reduced external interventions, higher logistics productivity, reduced uncertainty, and enhanced safety and security.

Reduced lead time obtained by reduced variance and average lead time due to fewer inspections, reduced waiting time due to better synchronization, and reduced slack time due to less uncertainty (Lee and Wang (2005)).

Enhanced resilience can be obtained through enhanced visibility and having corrective measures in place. It is expressed in terms of switching time and costs.

Better logistics service involves higher logistics reliability, reduced throughput time, and less logistics costs. Beyond the performance measures of its constituents, it could also be measured in terms of customer satisfaction.

Facilitated trade is considered to be the ultimate collateral benefit of security investments (Rice and Spayd (2005)). It is based on better logistics performance and as such is a consequence of operational excellence in the supply chain. However, it is also dependent on the cooperation of governmental institutions and benefits from reduced external interventions when confidence can be achieved through enhanced visibility etc. Better visibility and enlarged confidence in the reliability of processes may also facilitate trade by creating more favourable commercial conditions; in particular, suppliers may receive letters of credit under more favourable conditions, given that less risk is associated with the reception of the goods by the consignee.

6.4.5 Adverse effects of visibility

Although we focus on benefits of visibility, there are some possible adverse effects as well. First of all, overconfidence in the data or in general a wrong perception of the quality of the data may lead to wrong decisions, especially when the supporting methods are sensitive to data errors. In some cases, the use of robust methods may outperform the use of volatile methods with detailed, but erroneous, data. Moreover, the availability of confidential data may result in security issues.

6.5 Results of the benefits analysis

We have used two approaches to identify monitor and control loops that enhance performance in the supply chain in line with stakeholder requirements. Using the first approach, we have identified the main system features which were validated with the users. We have proceeded to identify the monitor and control loops that enable the expected benefits, and identify the roles that may arise as main beneficiaries.

Following the second approach, we have analyzed the trade lanes and have come up with a number of issues.

6.5.1 Trade lane analysis

In this section, we provide a generic analysis of issues in the various trade lanes, based on the workshops and interviews.

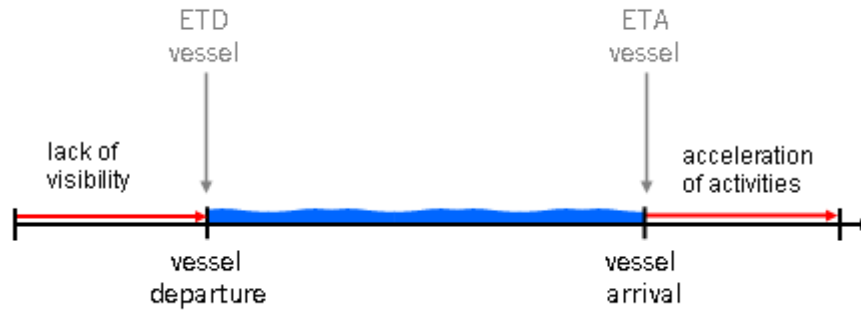

Fig. 48: decoupling points in the global supply chain.

One important issue relates to the existence of two decoupling points at departure and arrival of deep sea vessel. Once the vessel departure time is fixed, a delivery time window is established. The actual pick-up and transport of the container is not monitored. From the viewpoint of security, there is a lack of visibility in the export chain. Moreover, there are considerable time slacks in this process as the production and transport of the cargo is not monitored regularly and uncertainty associated with forecasts made far in advance is large. On the other hand, the expected time of arrival at the port of destination is unreliable to a certain extent; a delay of one or two days is not an exception. This uncertainty may affect the planning of import hinterland transport processes from port of destination. As time pressure is introduced and chain processes are accelerated, the impact of this uncertainty can be considerable. Even in a planning on a weekly basis, the delay of a container planned at the end of the week by two days may disrupt the production plan for the next week. Moreover, the departure time of the inland transport mode suffers from other sources of uncertainty, caused by processes at the container terminal, in particular the release of the container. As a result, the container may not arrive at its final destination in a timely fashion, which may not have been foreseen. A quantification of these cascades of time delays and the presence of time slacks in the chain are subjects of (statistical) analyses.

6.5.2 Potential trade lane benefits

Based on the trade lane scans and process analyses, some potential benefits have been identified, among which are the following.

- An important driver of second level benefits from visibility is constituted by possible cost savings in the administrative handling of information. However, these benefits are believed to be less relevant as opposed to the decrease of uncertainty caused by administrative delays, which may cascade throughout the trade lane.
- A basic driver of business value induced by visibility is the confidence, or reduction of uncertainty, in the container transport process. Visibility supports this confidence to the extent it includes more reliable timestamps of the milestones. Benefits that arise from confidence, or reduced uncertainty, are potential reductions of safety stock and slack times. An important example is the better prediction of the arrival of the sea vessel at the port of destination.

- The potential of having better forecasts of milestone timestamps, such as expected arrival of the vessel at the port of destination, may support the planning of hinterland transport and delivery.
- The ability to comply with (future) Customs regulations in terms of costs and time may represent more business value induced by visibility than the mitigation of business risk.
- The availability of supply chain data, including cargo information, may support Customs organizations to audit the trade lanes in such a way that inspections need not be triggered, except for random cases.
- Other potential benefits can be inferred from the monitor and control loops as identified from the required system features.

7 INTEGRITY Business Evaluation Survey

7.1 Conceptual model

Fig. 49 presents the business evaluation framework, which is the basis for the business survey design.

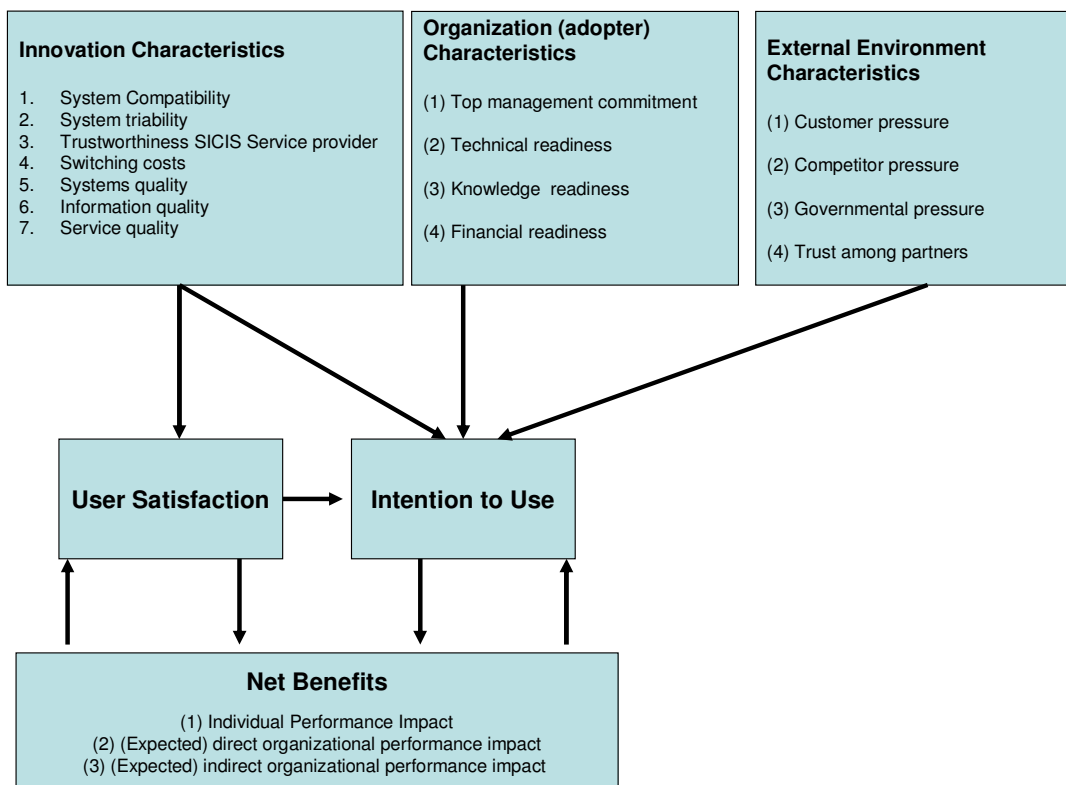

Fig. 49: Business evaluation framework

In this adapted business evaluation framework, three dimensions – innovation characteristics, organization (adopter) characteristics and external environment

characteristics, will affect the (intention to) use the system and the satisfaction of the users. The satisfaction of users and the intention to use and actual use of the system will lead to net benefits for the users. This contains a feedback loop. The (expected) net benefits influence the (intention to) use the system. If the (perceived) net benefits are low or decrease, the (intention to) use will be low or decrease.

Bearing this conceptual model in mind, a series of measurement criteria under each dimension are developed.

7.2 The survey design

The INTEGRITY business evaluation survey was conducted by using the on-line survey tool Globalpark, which is a leading international supplier of online feedback software for marketing research, human resources, marketing and customer-relations management. The survey consists of two parts:

- A common evaluation (for SICIS and SmartCM), which consists of a technical part and a business/user part;
 - (1) Technical evaluation
 - (2) User/business evaluation
- The SICIS-specific evaluation

Most of the survey questions are designed on a 7 point Liker scale from strongly disagree to strongly agree. Questions from the same measurement aspect are grouped in one section and a progress bar is programmed at the top right corner of the window. At the end of the survey, respondents are required to fill in their organization type, organization name, name of respondent and email address. Furthermore, respondents could voluntarily fill in their overall remarks/recommendations on SICIS system and overall remarks/recommendations on exploitation of SICIS after the project.

7.3 The survey target group

The intended users of SICIS consist of (representatives from) shippers, agents, terminals, logistics service providers, transport operators and authorities (specifically Customs). The survey invitation has been sent to the representatives of INTEGRITY partners, such as DHL, ECT, AS Watson, HPUK, YICT.

7.4 Findings of the Evaluation

7.4.1 Response

The first survey invitation was sent out on Jun 14th, 2010, after which three more follow-up reminders were taken place in order to increase the response rate. The last reminder was sent out on Aug 16th, 2010. The first INTEGRITY business evaluation survey is officially closed on Aug 30th, 2010, with duration of two and half months.

In total, 77 invitations are sent out to the intended users of SICIS system. 41 people started with the survey, yielding a response rate of 53%. Eventually, 10 respondents¹⁸ completed the full survey, which results a completion rate of 13%. The average time to complete the survey was about 20 minutes.

There are differences in backgrounds and SICIS use experience. ECT is the first adopter and the heaviest user of the SICIS system within total 52 weeks of previous use. Logistics providers (BAP logistics, DHL Global Forwarding and ISL) are the second heaviest user group with an average of 40 weeks. AS Watson, as shipper, uses the SICIS system rarely (only once half a year ago).

7.4.2 Perception of SICIS

This is an overall evaluation of the functionality of the SICIS system itself. It is measured by the system compatibility, the system triability, the provider trustworthiness, the switching costs, the SICIS system quality, the SICIS information quality and the SICIS service quality.

Fig. 50 presents the outcomes of the survey concerning perception of SICIS system. As one can see, on a 1 to 7 scale, the average score of the SICIS system is about 4.7. However, if taken a look at the measurement scale from strongly disagree to strongly agree, 4.7 only represent a slightly more agreeable than “neutral” (4) and less than “slightly agree” (5). Among all aspects, provider trustworthiness scores the highest (5.75) among the rest, which means most of the users perceive the SICIS system as trustworthy and committed.

According to the observation, switching costs in general is considered to be relatively low since most users perceive SICIS system as easy to be used parallel to existing system.

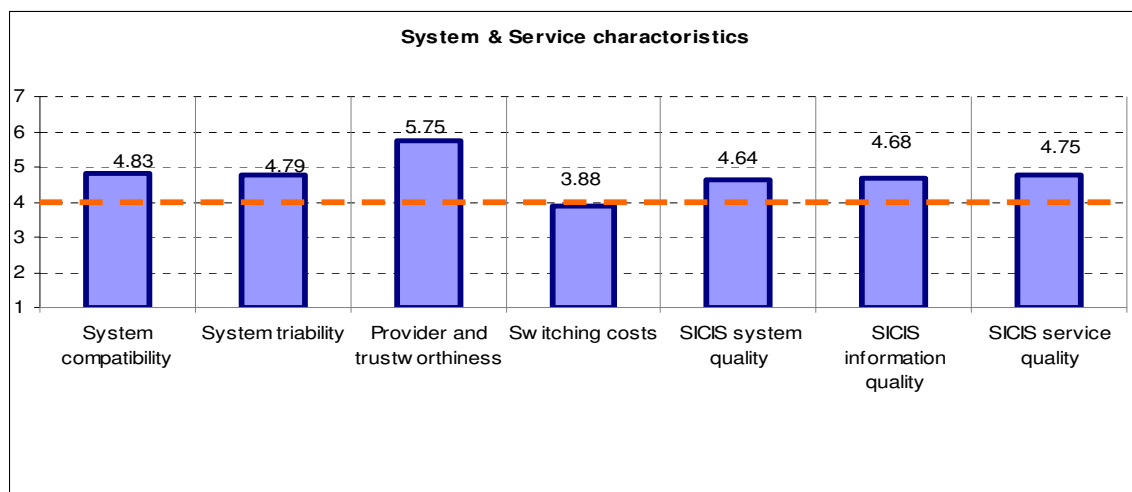

Fig. 50: Evaluation of the SICIS system

In the following section, a group of the most representative sub-items that influence the perception of SICIS will be discussed.

¹⁸ RSM, ISL, HPUK, ECT, AS Watson, DHL, UK Customs, LSP, BAP, Cargo Services Far East Limited

System Compatibility

Fig. 51 presents the outcome of the sub item – system compatibility evaluation. Respondents agree that SICIS system could be a good fit to their organization and existing IT infrastructure. However, they have to get used to work with SICIS system at their daily jobs.

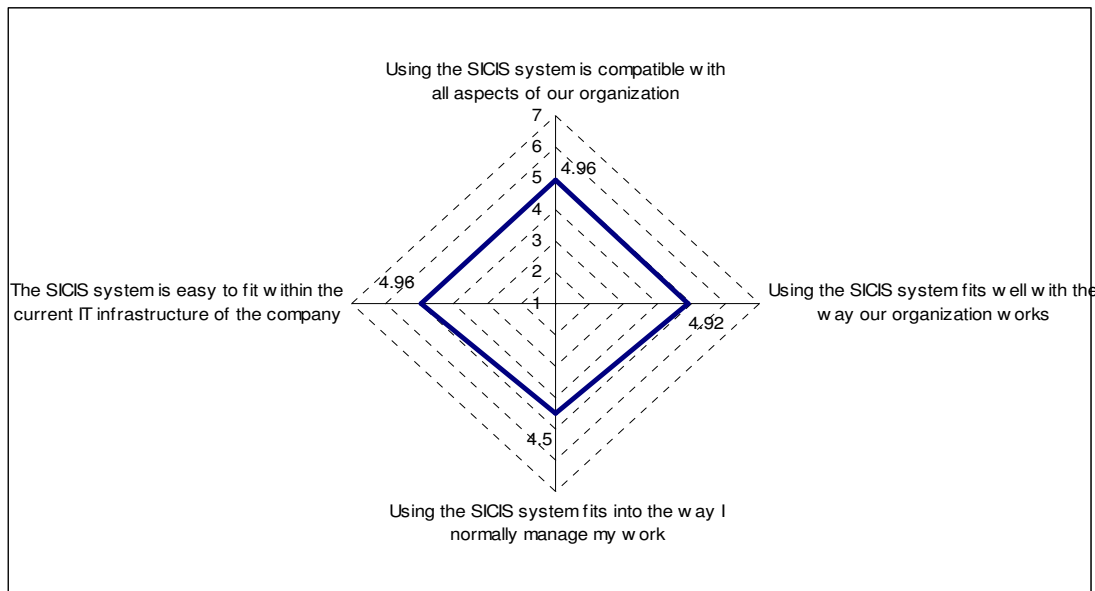

Fig. 51: Evaluation of System Compatibility

SICIS System Quality

SICIS system quality is measured from the perspectives of the system reliability, the response time, the authorization, the usability and the personalization of the system, as shown in Fig. 52. As illustrated in the figure, respondents report that the SICIS system is relatively easy to operate and it is able to provide information without delays.

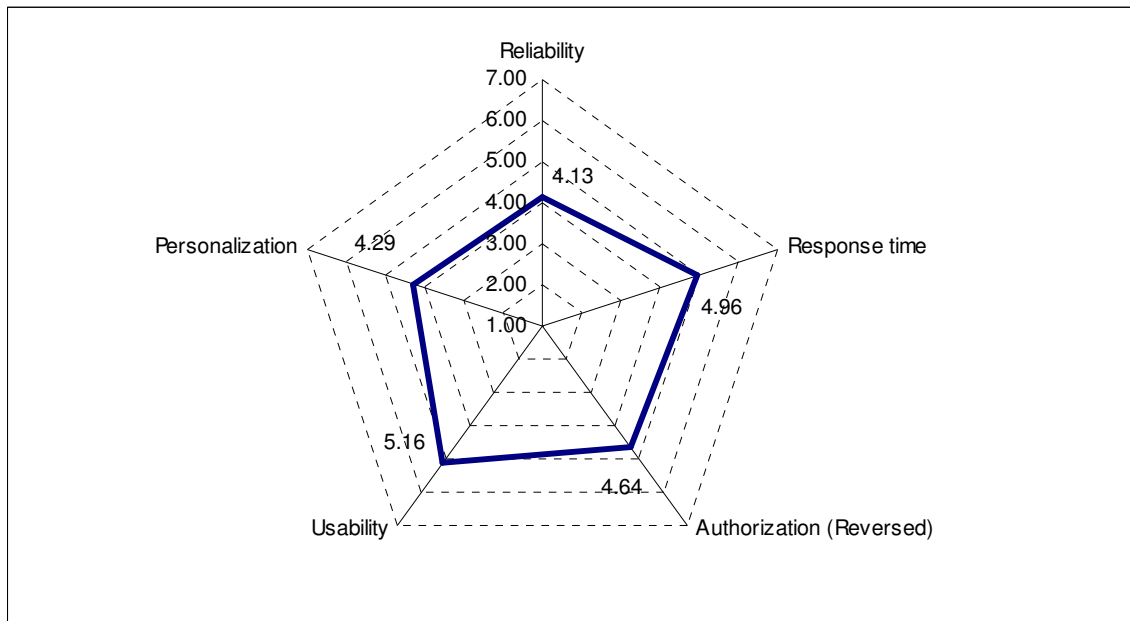

Fig. 52: Evaluation of SICIS System Quality

Comparing to the system usability and the response time, the system reliability and the personalization scores just above 4, meaning slightly agreeable than neutral. According to the survey, respondents think SICIS is dependable in terms of access, uptime and availability. The concerns that drag the reliability evaluation down are due to the unexpected/inconvenient down times, since SICIS is still in a phase of development.

SICIS Information Quality

Fig. 53 presents the evaluation of the SICIS information quality in details. As shown in the graph, the information ease of understanding, the timeliness and the accuracy are generating positive feedbacks, meaning information delivered by SICIS system is easy to understand, in a timely fashion and in an accurate form. Among all measurement criteria, information completeness scores the lowest 4.16. The main reasons are as follows. First, the Customs is not satisfied with the information provided by SICIS because information provided does not cover the full scope of its data need, for instance not all parts of supply chain are covered, there are data elements missing. Second, most of the respondents give a 4 (neutral) to the survey questions. This could be interpreted in two ways that either because the SICIS system is not providing them the exactly information they need, or the survey questions are not specific enough. Since the evaluation only considered the basic SICIS version, it is expected that these criteria will score better in the 2nd evaluation, once more modules are available and the SICIS system is more stable.

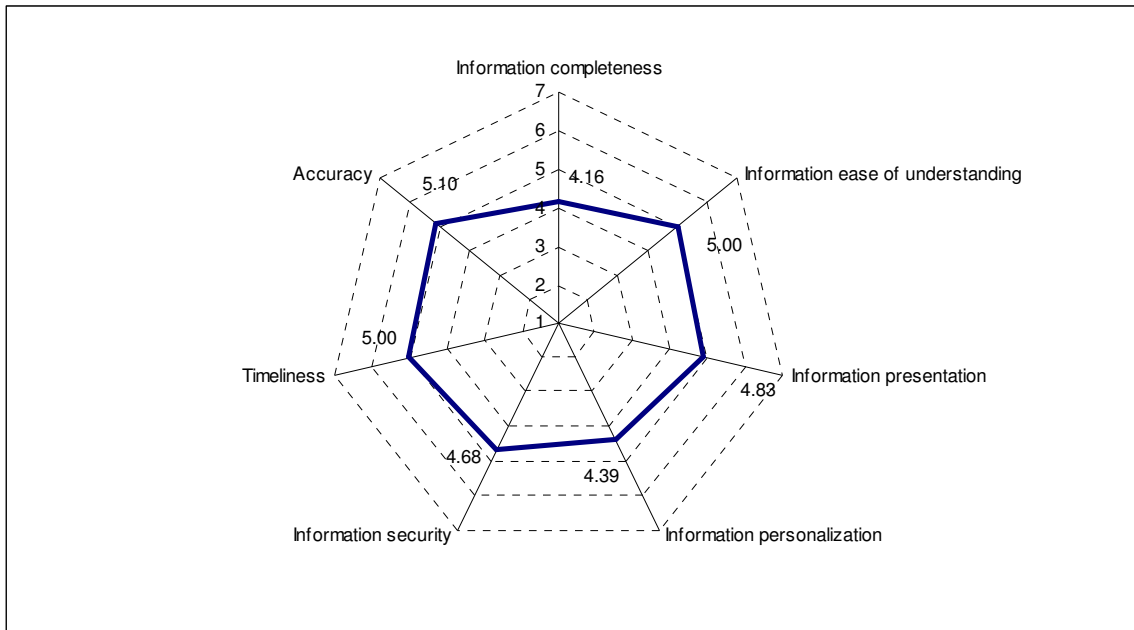

Fig. 53: Evaluation of SICIS Information Quality

Switching Costs

Fig. 54 presents the evaluation of the switching costs. In this graph, the feedbacks are partially reversed to keep the correlations identical (as marked in the graph). For instance agreeing that the SICIS system could be used parallel to existing systems indicates a low switching cost.

According to the observation, the switching costs in general is considered to be relatively low since most users perceived SICIS system as easy to be used parallel to the existing system and there are not much costs involved when connecting and using the SICIS system.

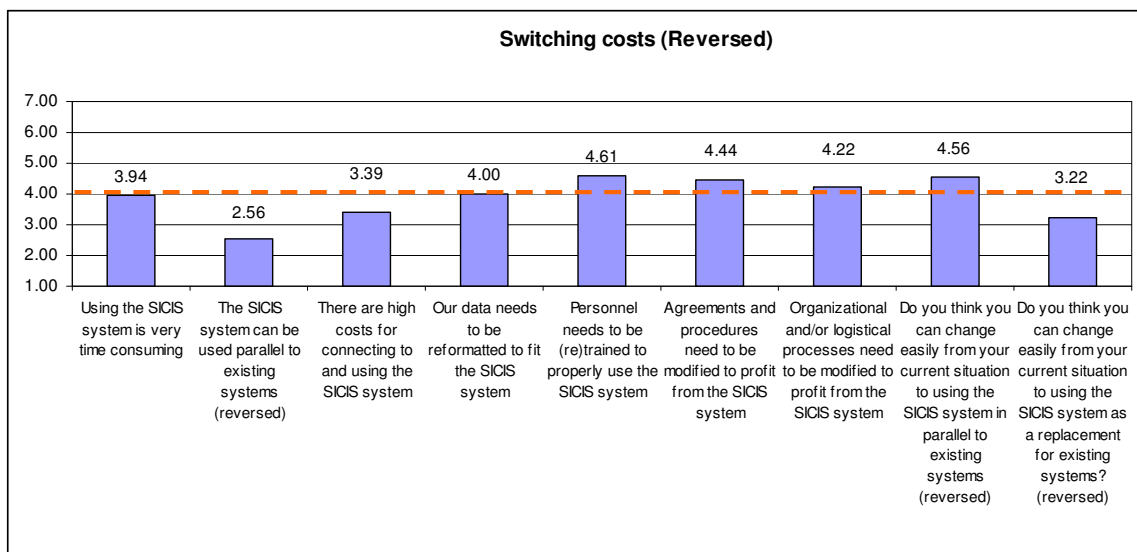

Fig. 54: Evaluation of Switching Costs

There are some variations in how to use the SICIS system among different respondents. For some of respondents who do not have such a similar system in place, it is easy to use SICIS system as a replacement, therefore, resulting extreme low switching costs. Yet there are companies which already use other systems to provide them with some sort of tracking information, in these cases switching costs involved will be relatively higher. The factors that generate the most switching costs concerns are the personnel training, the agreement and procedure, and the data format.

Authorization

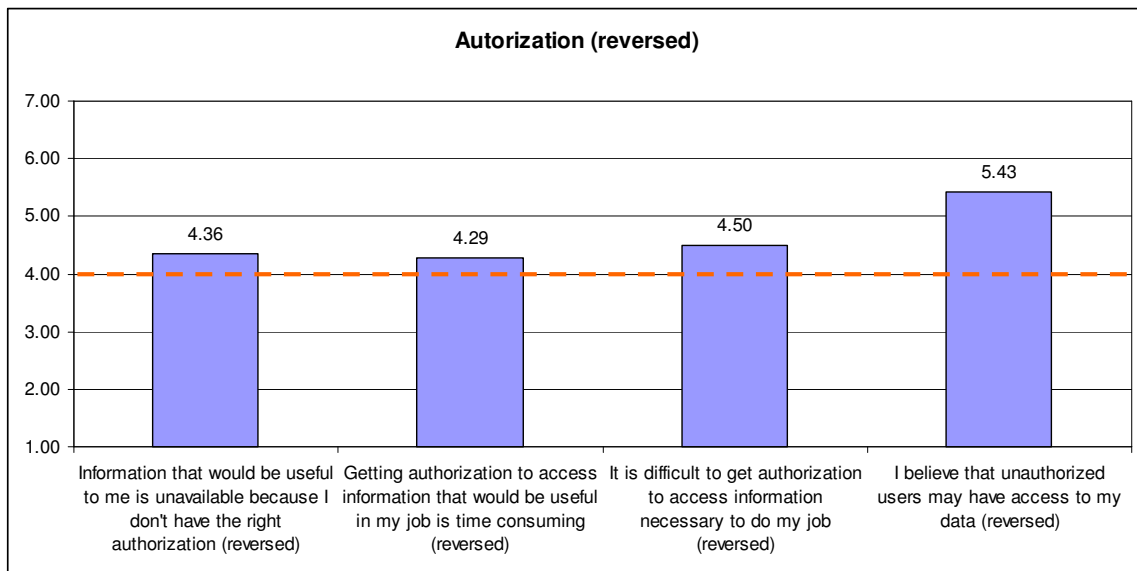

Fig. 55: Evaluation of Authorization

Fig. 55 presents the feedbacks of the authorization among respondents. As shown in the graph, most users trust SICIS has only provided relevant data to authorized users, meaning rarely unauthorized users may have access to the data. Moreover, most respondents think it is rather easy and quick to get the authorization from SICIS, which bring positive influences to the evaluation of SICIS system. Additionally, according to the user feedback, authorization should be well defined among the role of the users and the information they may access.

7.4.3 Organizational Readiness

The organizational readiness is measured by the top management commitment, the technical readiness, the knowledge readiness and the financial readiness, as shown in Fig. 56.

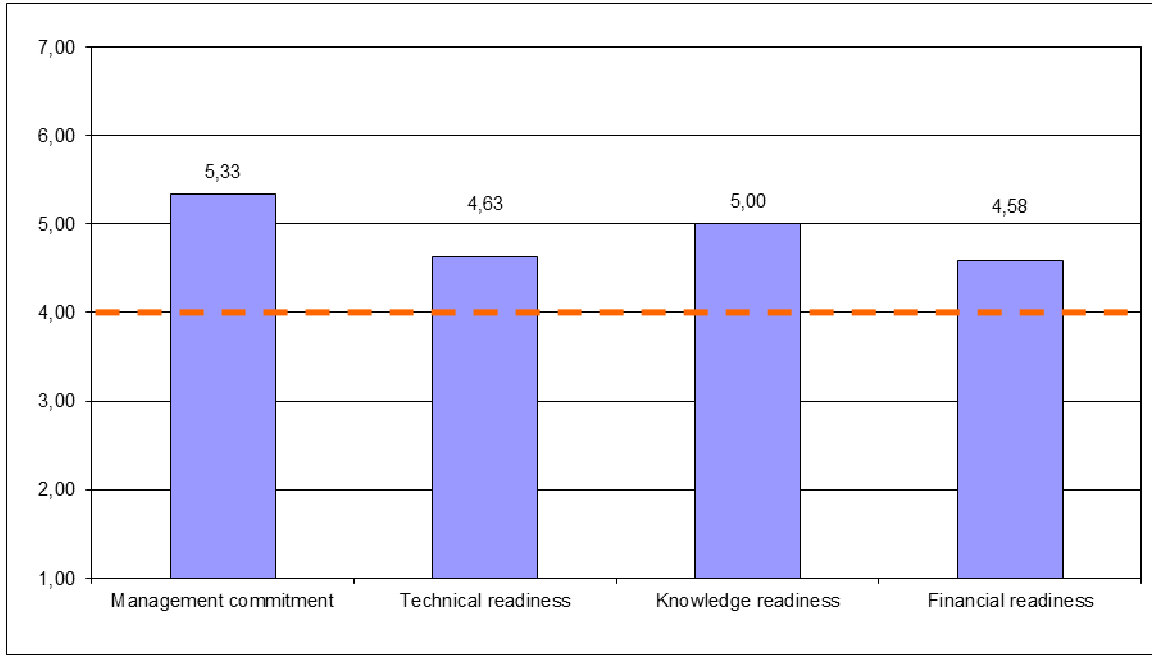

Fig. 56: Evaluation of Organization Readiness

Top management readiness scores the highest 5.33. It could be interpreted that top management within the use companies involved have realized that there are potential benefits of using the SICIS system. When taken a closer look at the original data, most of the operators from the country of destination (i.e. ECT, Port Authority UK, and logistics service providers) have a higher management commitment since they could be directly benefited from the SICIS system than the operators from the country of origin. Furthermore, most of the operators with high management commitment have a relatively high knowledge readiness, technical readiness and financial readiness.

For operators who are less positive about SICIS system, most concerns are coming from financial and technical issues.

7.4.4 External Pressure

The external environment characteristics are measured by the customer pressure, the competitor pressure, the government pressure and the trust among partners.

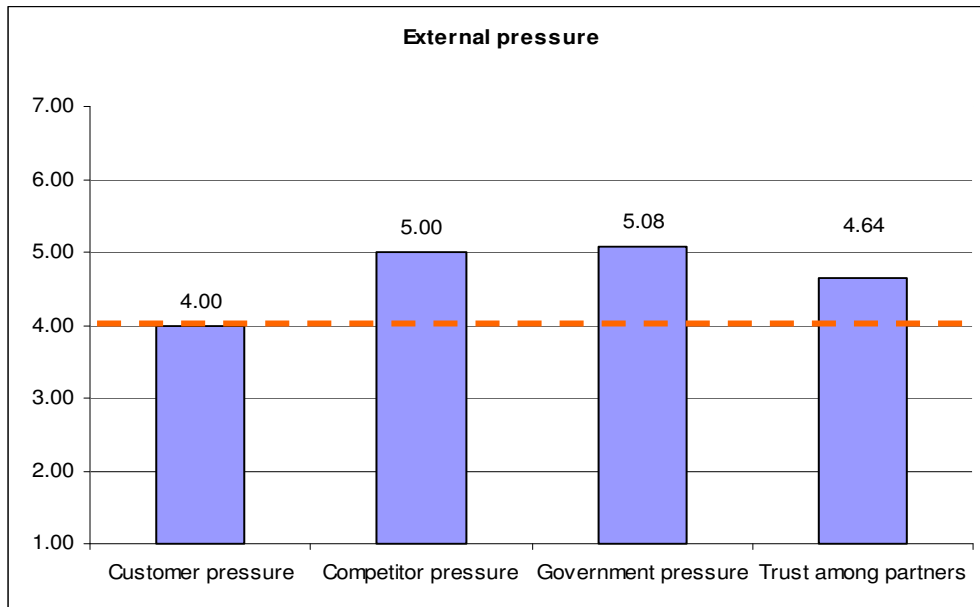

Fig. 57: Evaluation of External Pressure

As one can see, most of the external pressures are coming from the government and the competitors. All respondents agree to a certain extent that the SICIS system can help them to fulfil legal requirements / laws from authorities (e.g. AEO). All operators from the country of destination (ECT, Port Authority UK, logistics providers and consultant) agree that using the SICIS system will result in a corporate improvement of the position towards competitors. Moreover, although there is established trust among partners, most of the respondents prefer to only share relevant information with the relevant partners.

7.4.5 User Satisfaction and Intention to Use

The survey has found that most of the respondents agree that SICIS is a useful tool to increase visibility of the supply chain and will recommend it to other organizations. Some respondents suggest to improve the user interface of SICIS.

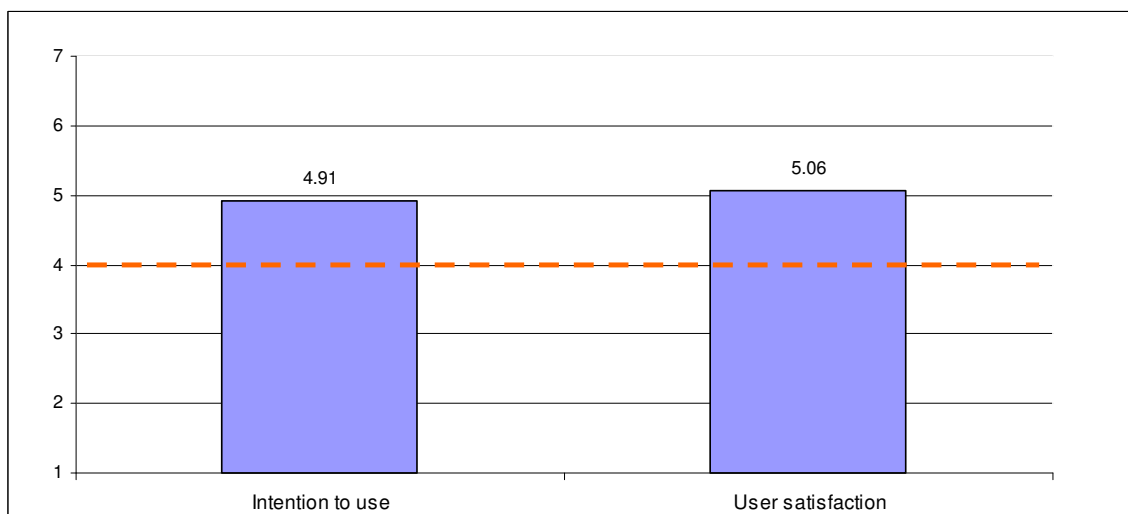

Fig. 58: Evaluation of User Satisfaction and Intention to Use

Fig. 58 shows the user satisfaction and intention to use of the SICIS system. As shown in the graph, the intention to use the SICIS system is slightly lower than its user satisfaction. The intention to use is influenced by the perception of SICIS, the organizational readiness, the external pressure and the user satisfaction.

7.4.6 Expected Benefits

Expected (net) benefits are measured by the individual performance impact, the expected direct organizational performance impact and the expected indirect organizational performance impact in this survey. Fig. 59 provides an overview of these three measurements.

As shown in the graph, respondents are expecting positive benefits from the SICIS system. According to the evaluation, the direct impact of organizational performance is better recognized than its indirect impact. Furthermore, In general, respondents claim that the use of SICIS has a positive impact on their individual performance. For instance, most respondents agree that by using SICIS system, they can make better decisions and accomplish things more quickly.



Fig. 59: Evaluation of Expected (Net) Benefits

The details about how respondents perceive each impact is discussed in the next three sub sections.

7.4.7 Individual Performance Impact

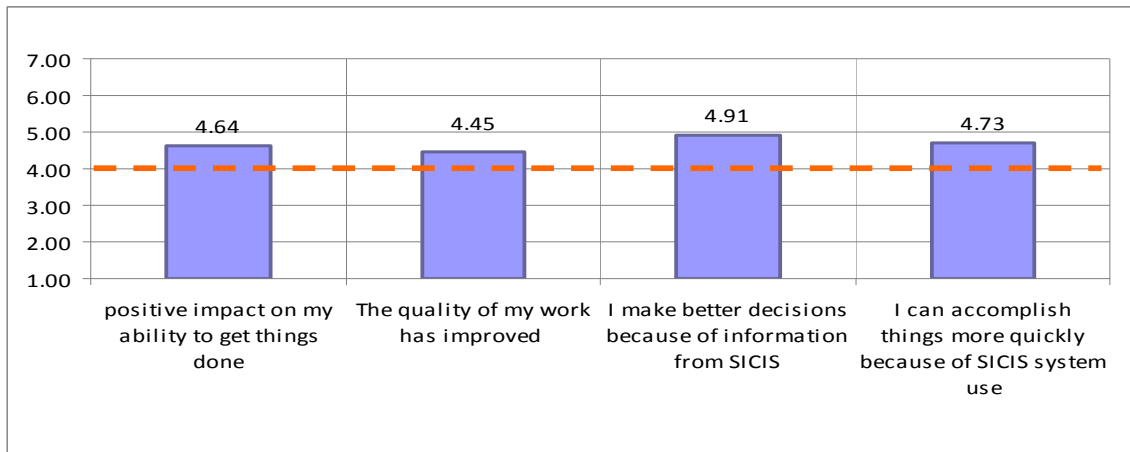

Fig. 60: Evaluation of Individual Performance Impact

Observations show that most of the respondents admit that information provided by the SICIS system has a significant positive influence in their decision making process. Furthermore, respondents agree that the use of the SICIS system helps users to accomplish thing more quickly. Among all users participated in this survey, users who actually need the information from SICIS for their daily operation confirm a significant positive influence of the SICIS system to their individual performance, for instance logistics service providers at the country of destination, Port Authority.

7.4.8 Expected Direct Impact on Organizational Performance

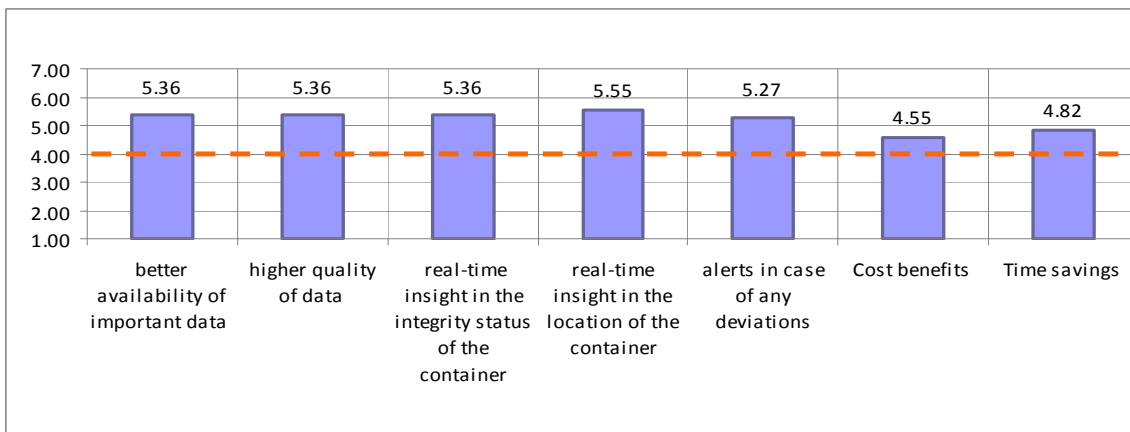

Fig. 61: Evaluation of Expected Direct Impact on Organizational Performance

The expected direct organizational performance impact scores the highest 5.18 among other factors. The biggest direct impact on performance is expected from the possibility to gain real-time insight into the location of the container. Other direct impacts as perceived by the users are a better availability of important data, a higher quality of data, real-time insight in container integrity and alerts in case of deviations.

However, there are slight doubts about the costs benefits and the time saving. It could be interpreted that it is costly and time consuming to implement a new system next to the

existing system in the beginning phase of launching SICIS. At a later stage, when the SICIS is well rolled out, the cost saving and time saving benefits should be able to derive. Therefore this measurement variable should be able to generate a higher score after this phase.

7.4.9 Expected Indirect Impact on Organizational Performance

The expected indirect organizational performance impact is rather positive as well. Among all factors, having a reduced risk profile (with positive effect on Customs inspection) is the most agreed and recognized indirect impact on organizational performance. The second most recognized indirect impact is the supply chain visibility. Almost all operators from the country of destination confirm that their supply chain efficiency could be improved by the increased visibility (offered by the SICIS system).

The rest of measurements score variously due to different organization interests. However, in general there is significant positive indirect impact on organizational performance.

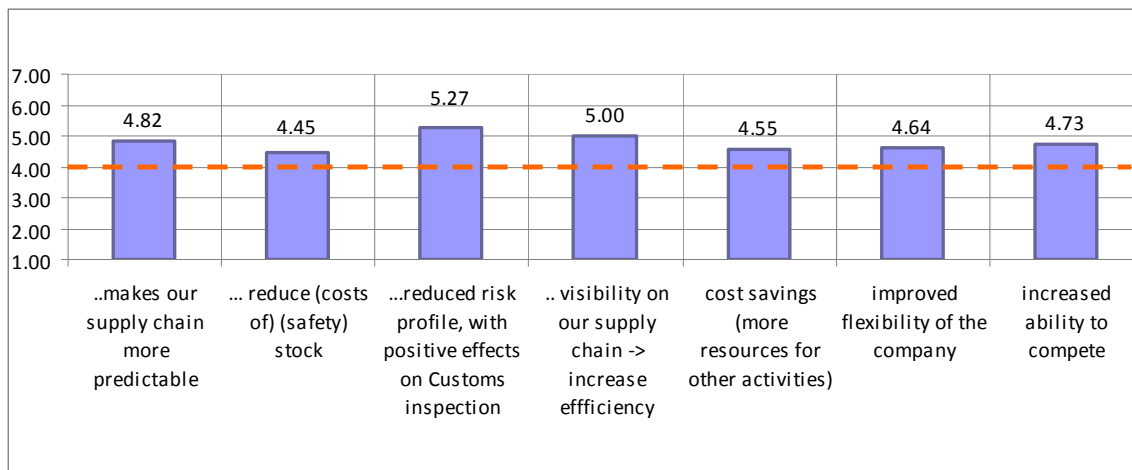

Fig. 62: Evaluation of Expected Indirect Impact on Organizational Performance

7.4.10 SICIS modules

Besides the common evaluation m, the business evaluation questionnaire contained a number of questions which are specific for the SICIS platform.

In general, SICIS modules score a 4.86, between neutral and slightly satisfied. To take a closer look at each module, the container tracking and the user management generate the most satisfaction among the users. The procedure for container security devices gives the most doubts and dissatisfaction (which is to a large part outside the scope (of influence) of INTEGRITY and rests with Container Security Device providers).. Furthermore, the telephone helpdesk, the vessel tracking and the user manual can be further improved.

Additionally, evidence shows that the direct beneficial users of the SICIS system, for instance, shipper, logistics providers, terminal, have a stronger satisfaction rate than others.

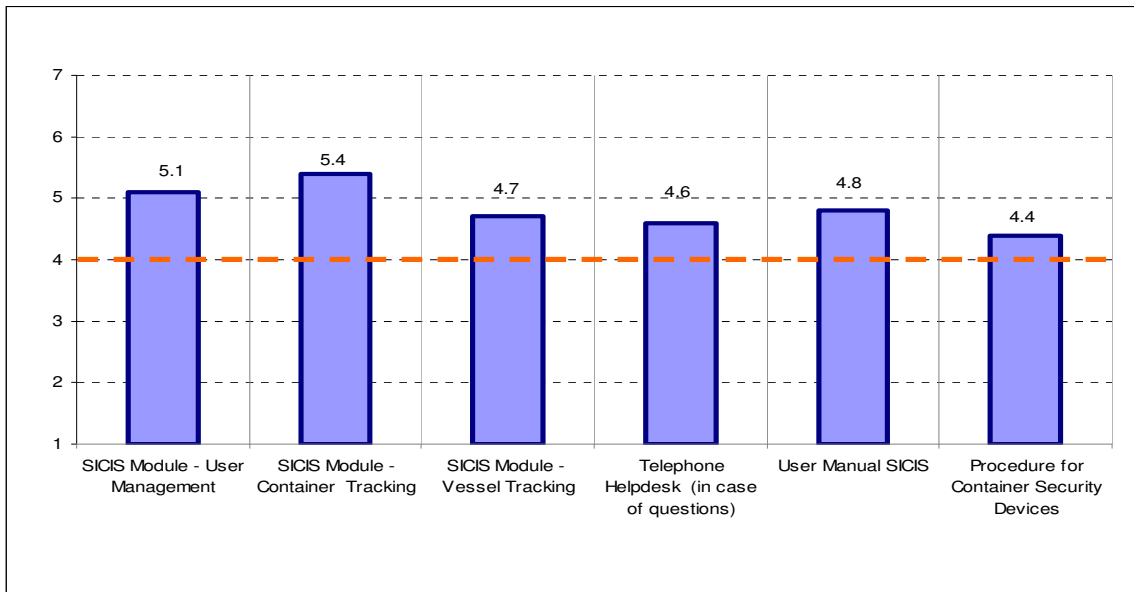

Fig. 63: Evaluation of SICIS Modules

7.4.11 Business Model for SICIS

According to the observations of the survey outcome, users prefer to get the SICIS service via user interface and SICIS website with a direct connection to their in-house systems. Furthermore, it seems that users care more about where to get the SICIS service (via SICIS website or an existing platform) than how to get the data (via a direct connection with existing in-house system or an existing platform). Detailed discussions are presented below.

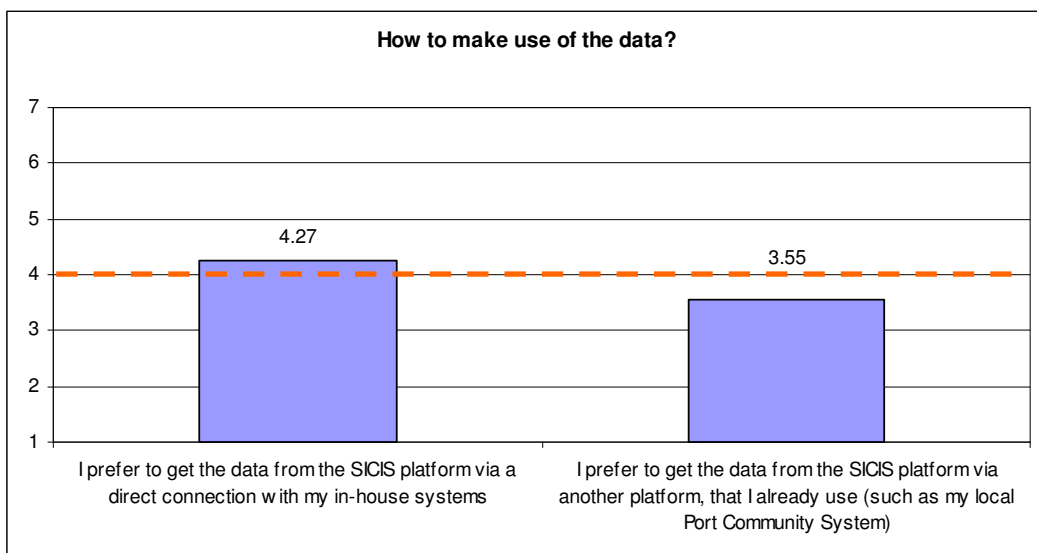

Fig. 64: Feedback on how to make use of the data

Fig. 64 indicates the preferences of how to make use of the data. As illustrated in the graph, most of users prefer to get the data from the SICIS platform via a direct connection

with their in-house systems. Instead of integrating with an existing platform, SICIS should offer direct connections to the existing platforms of different organizations.

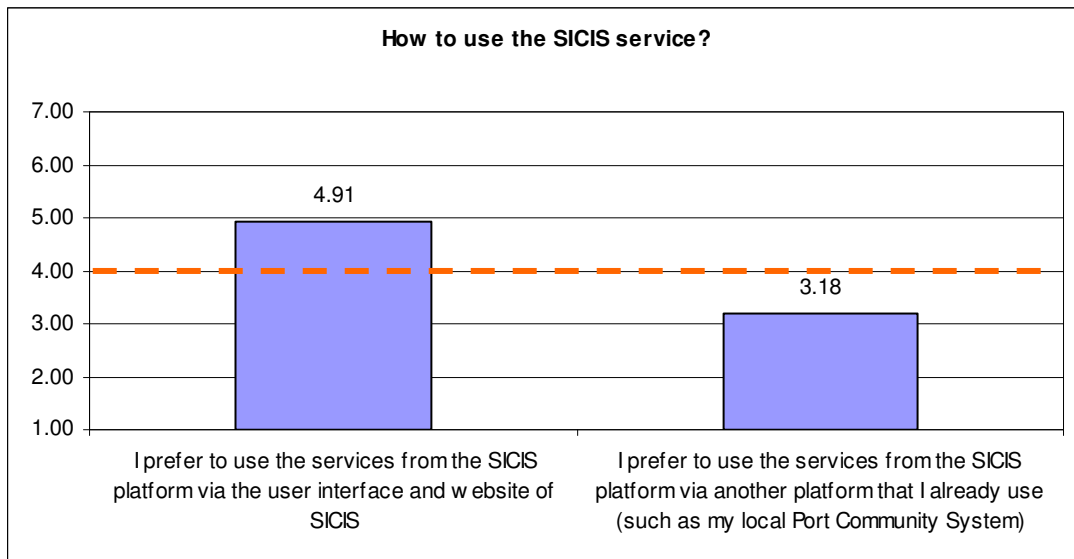

Fig. 65: Feedback on how to use the SICIS service

Fig. 65 shows the possible business models for SICIS service and their user preferences. As shown in the graph, almost all users prefer to use the SICIS service via the user interface and SICIS website.

7.4.12 Provider of SICIS

According to the survey outcome, the trusted provider for SICIS system should be a perceived neutral organization, a commercial organization, or collaboration/consortium. A few most nominated names are “a third party”, “Trade Consortium” and “shipping Lines”.

The common characteristics of these most nominated provider are that the provider should be neutral and objective to the key users. Since the success of the SICIS system depends much on the collaboration and information sharing of the entire supply chain, a fair and trustful foundation is necessary in the first place.

Besides the trust issue, users also propose that the provider of the SICIS system should be able to market the system and get it used by as many parties as possible.

7.5 Conclusions of the business evaluation

The overall feedback on the SICIS system is rather positive. Most of the users are aware of the potential benefits of implementing and using the SICIS system. However, organizations in different parts of the supply chain have different interests.

Users that could benefit directly from SICIS system are more actively involved in the adoption and have more positive experiences. In this case, the most active users of the SICIS system are the operators from the country of destination, for instance, ECT and the logistics service providers.

7.6 Limitations and Recommendations

The survey design

The cost saving perspective of the SICIS system should be supported and communicated with better arguments. Most of the operational benefits, such as better real-time insight information, reduced risks are well perceived. However, whenever it comes to cost saving, people become less enthusiastic and ambiguous.

The acceptable SLA (with regards to response time) question is unclear since the following answers are obtained: 2 hours, 4 hours, real time, less than 1 minutes, 10 seconds, don't understand the question, etc. This variable should be better defined and measured in a clearer way.

The survey overall

In general, this survey covers various perspectives of the SICIS platform, including SICIS system quality, organizational readiness, external pressure, performance impact, satisfaction, intention to use, SICIS module satisfaction, etc. However, the outcomes sometimes are too generic, and should be made more specific. Since each party involved in the chain has different interests in some specific fields, having users with different interest at the same time might bring in bias, thus resulting a diluted effect on the SICIS evaluation. In the 2nd measurement, it might be interesting to define user groups and adopt different versions of survey to its corresponding user group for more specific feedback.

In this survey responses, plenty of “neutral” are generated as feedbacks. It could be interpreted into two ways. It could be either participant does not have much experience on that specific issue yet, or SICIS is offering something, but not all exactly what he wants. To increase the adoption rate, SICIS should be able to identify exactly what the users want and offer exactly what they need.

Participation

The purposes of this evaluation survey is to assess whether project objectives have been met, and if not, where and what should be modified. Therefore, the input of the users at the design phase does not only help the system development, but also give the users the opportunity to bring in their own ideas for their future benefits. Therefore, a good system can only be designed with user feedbacks.

Out of 77 user invitations, only 10 people filled out the survey, which results a 13% completion rate. Within the 10 people who carried out the survey, few users rarely have any experience with the SICIS system, which might result bias in the survey research. It is understandable that this is the beginning phase of a pilot project and not many people are actually using it yet. Hopefully along with the development of SICIS, more users will get involved in the second INTEGRITY survey to improve the system and service.

Moreover, although only 10 people filled out the survey, they represent most segments of the container supply chain. The lack of feedback from shipping lines and ICT providers could be another limitation of this survey.

8 The SICIS business model

In this deliverable it is about developing value propositions for a container tracking service. To accomplish this, a business model framework is being used. With a good business model it is possible to justify the usefulness of certain activities or services in such a way that they will add value for the customers and the company who is providing these products or services.

There are several different definitions of a business model. Magretta mentioned a definition in an article about business models: “Business models describe, as a system, how the pieces of a business fit together” (Magretta (2002)).

Timmers’ definition of a business model is often cited in other studies. His definition of a business model is (Timmers (1998)):

- An architecture for the product, service and information flows, including a description of the various business actors and their roles; and
- A description of the potential benefits for the various business actors; and
- A description of the sources of revenues.

Osterwalder (2009) defined a business model as: “A business model describes the rationale of how an organisation creates, delivers and captures value” (Osterwalder & Pigneur (2009)).

To do so it is important to know what a business model is and what it does. The business model literature is still quite immature. Osterwalder wrote one of the first studies about what business models are and how to create one (Osterwalder (2004)). After this study the business model template has been revised several times. In this deliverable the latest model of Osterwalder is used to create a business model for the container tracking service. Fig. 66 illustrates the nine building blocks of a business model according to Osterwalder and Pigneur.

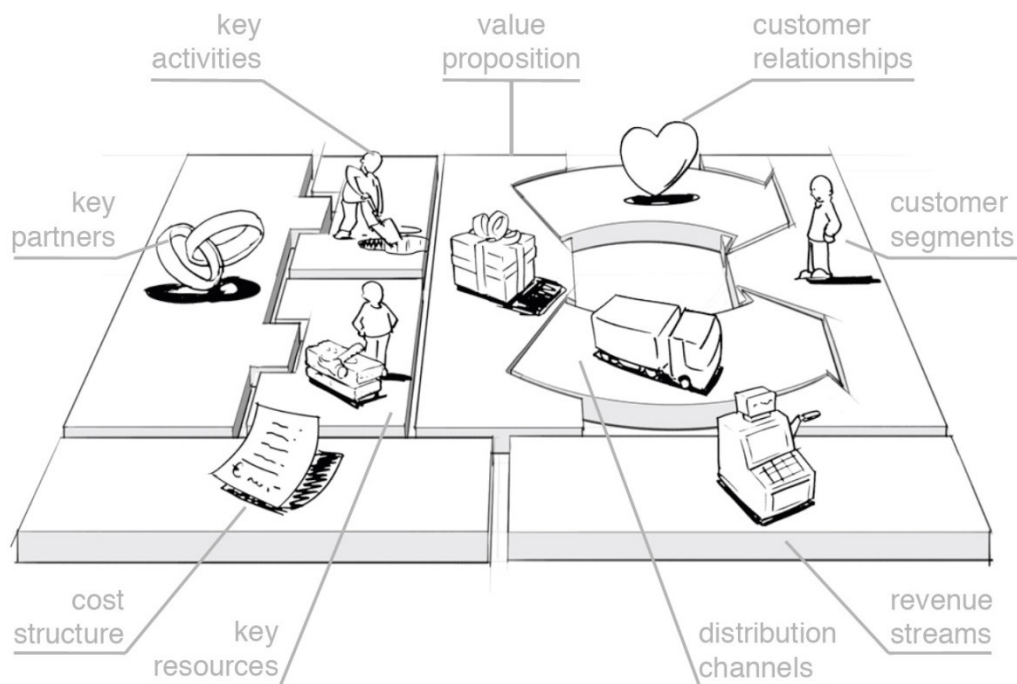

Fig. 66: Nine building blocks of a business model (Osterwalder & Pigneur (2009))

The value of a business model can be derived from these different variables (Hedman & Kalling (2003)):

- Returns to all stakeholders
- Returns to the organization
- Market share
- Brand and reputation
- Financial performance

The business model of Osterwalder is very practical in usage. The model gives the possibility to analyse and create a business model in a structured and systematic way. The building blocks, which will be discussed later in this chapter, show where the difficulties are for the specific business model.

The other advantage is that this business model is understandable for (potential) customers. Some other business models are very scientific and therefore hard to understand for customers.

The business model can be seen as a (conceptual) link between information systems (the technology), the organization and the strategy (Osterwalder & Pigneur (2003)) illustrated in the figure below.

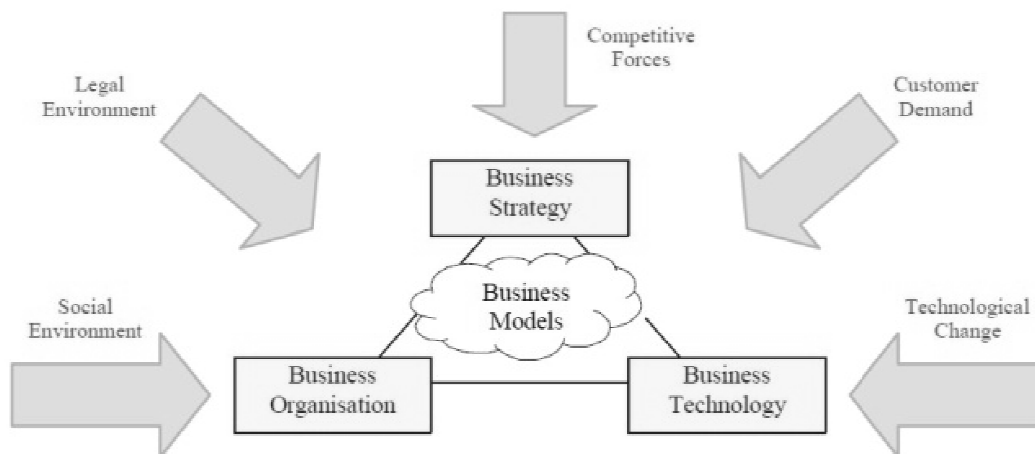

Fig. 67: The Business Model environment (Osterwalder & Pigneur (2003))

8.1 Value Propositions

In this paragraph all relevant value propositions will be described. First all relevant benefits which were found during the study will be discussed. Secondly these benefits will be structured in a framework. Finally certain offers are being proposed to put into the market.

8.1.1 Benefits

All the benefits which were found during this study will be presented here. Every benefit has a short title. Directly below there is a short, one line description which summarizes the benefit. These are especially useful when the benefits are presented to a (potential) customer.

The benefits are structured in operational visibility and cost and time savings. Operational visibility derives from the information which is provided by the devices. These operational visibility benefits lead to costs and time savings sometimes directly or indirectly. Customers need to act on the data they have collected to get these benefits.

Operational visibility

Responsible stakeholder

“Know who is responsible for your cargo anywhere, anytime.”

During the journey containers are handled by different stakeholders. Consequently, the responsibility of the container changes during the transportation.

If something gets stolen from the container, it is usually not clear when and where the container was opened. With a tracking device on the container it is possible to know when and where the container has been tampered. The advantage of this information is that by knowing the opening location it is possible to shift the costs for theft to the responsible stakeholder who was responsible for the container at that moment.

Location information

“Know where your container is, anywhere, anytime”

This is the most basic benefit. By knowing the location of the container you improve the visibility.

Lost prevention

“Never lose your valuable cargo again.”

By tracking a container the current location is known. Therefore it is not likely that a container will get lost during the journey or even at the terminal. This last benefit is not for eSeal and container tracking devices without GPS. If the devices have no GPS tech so the container can still get lost in the terminal. With the RFID reads the terminal will be known but the exact location in the terminal is not.

Diversion monitoring

“Know where your cargo got diverted”

Although certain containers have a well plan schedule to go from point A to B, the transportation company often does what suits best in their own planning. This can cause time delays in the journey and also potential risks if the container is unloaded at a port (e.g.: theft risk). With this information customers can get a view on their planned and actual routes and act on it accordingly.

Diversion identification

“Identify possible diversions as soon as they occur”

With the information the tag is providing it is possible to know where and when certain disruptions occur during transit. Because the tracking device is also able to give the user more timely, accurate and complete information costumers can better act on these disruptions.

Improve reliability of ETA's

“Estimate arrival times of your cargo more accurately”

If you know where a container is, it is possible to estimate the arrival times. If this information is combined with historical data from other containers about transit times, this information can be very accurate.

A next step (and indirect benefit) of this information is that the customer can see where certain delays occur and act on it (process redesign) to prevent these delays in the future.

Container integrity

“Know where and when the container door was opened.”

The integrity of the container means that the door has not been (unwanted) opened during the journey. The door open alert gives information when the door is opened. If the tracking device has a GPS receiver this information can be combined and the user will get information about the location where the container is opened.

Some door openings are planned for example if Customs open the container. With this information users can verify if the door openings were regular (e.g. by Customs) or irregular and therefore a potential risk (theft of cargo).

Theft prevention

“Avoid unnecessary theft of your cargo”

With information available from earlier thefts of cargo (unexpected door openings) that was recorder from the container tracking devices, these areas can be avoided or more security measure can be taken to prevent theft in the future. Although this is not a direct benefit, historical data can reveal patterns and help to prevent this in the future.

Cargo conditioning

“Real-time information on the condition of your cargo.”

Abnormal sensors readings notify the information system that something is wrong with the cargo. These sensors reading can differ from temperature, humidity, shock, light and so on. If there is a sensor available for the kind of value you want to measure it should be possible to add this to the device according to several providers.

There are many different sensors on the market and therefore several sub benefits do exist. To explain what kind of benefit a sensor can have an example of a temperature sensor will be discussed in the next paragraph under “Prevent value loss of cargo”.

Damage monitoring

“Know when your cargo has been compromised.”

With shock sensors the tracking device can give information if the container has been dropped. Consignee’s can act on this event if necessary.

Brand protection

“Ensure your customers they get genuine products.”

If you have tracking devices on product which are genuine you can tell which containers contain counterfeit products and therefore protect your brand. This is especially useful with high value cargo which is often counterfeited.

Cost and time savings

The operational visibility benefits mentioned above are already valuable for customers. Nevertheless the question arise “so what?” Companies are interested in services where they can make or save money and time which will help them to achieve operational excellence. Especially in times of economical downfall companies are reluctant to invest in products or services without a clear view on where the actual savings come from. Therefore another set of benefits is presented here.

Lower insurance rates

“Lower your insure rates.”

By knowing who is responsible for the cargo (know when the container has been opened and know where a container is at a certain point in time) is reduces risk for the insurance companies. When the risk declines, the insure rates can drop as well. Several container tracking service providers already managed to reduce the insurance rates for their customers due to this enhanced visibility.

Reduce lead time

“Reduce lead times of your cargo”

By knowing all the information about containers (visibility) there is a possibility to improve the supply chain in a way the waiting time for the cargo is limited to the minimum. When the trade lane is optimized this can lead to the reduction of lead times.

Reduce inventory

“Reduce inventory by using your containers as a virtual warehouse.”

By using containers which are still in transit as a virtual warehouse, the actual inventory levels can be decreased. If the ETA's of containers are reliable there is no need to hold inventory in the warehouse (JIT principle).

Prevent unnecessary demurrage costs

“Get visibility in your demurrage costs.”

With the visibility the holding time of a container can be reduced to the minimum. The information of the location of the container also gives the possibility to check if a container actually was holding at the terminal. Nowadays there is limited visibility concerning the duration of the container in the terminal.

Prevent costs of stolen cargo

“Prevent costs of stolen cargo.”

With a device on the container the location and time of the tampering of the container is available. The responsible stakeholder can be identified and can also be held responsible for the theft. Besides that the historical data can help the shippers/consignees to prevent theft in the future.

Prevent value loss of cargo

“Prevent value loss of your cargo.”

A container full of cargo is valuable. If, for some reason, the value of the cargo is compromised it is important to know this as soon as possible. An example of the possible costs savings which can arise when this information is visible is described below. In this example a temperature sensor is used.

De-risk containers at Customs

“De-risk your container for Customs because of maximum visibility and integrity information.”

If the door was not opened after the Point of Loading (POL) and there is maximum visibility about the route the container took, Customs are willing to de-risk certain containers. On the other hand an unexpected door opening can trigger Customs to increase the risk factor on that particular container.

This is an advantage for Customs and shippers. Shippers know which container have the potential risk to get inspected; Customs is able to make a better risk assessment due to the integrity and visibility information.

Temperature sensor

The sensor will measure the temperature of the cargo inside the container. In the example of SAVI Network an alert message will be send to the system when the temperature reaches a certain level which has been preset. There is also a possibility to monitor and store the temperature data for further analyses later.

Raytheon has developed technology which allows the user to adjust the cooler settings to adjust the temperature inside the container. Besides that the temperature sensor can also help to adjust the cooling setting (switch it off when possible) to save energy (and costs).

There are also some operational benefits of monitoring the temperature. If a container full with fruit is being transported from point A to B and some containers were not able to maintain the optimal temperature. This information is not available without the sensor. Cargo owners can now react on this information and can save money and time by doing the following:

- Plan to handle these containers first to prevent them from perishing and keep them valuable
- Already ship a new load of fruits to prevent unnecessary delays for the buyer of the fruits

All sensor information has certain benefits. Because there is information available on the cargo during transit, the customers is able to react on it even when the container is still at sea. This way it is possible to improve the handling process to maintain the value of the cargo and prevent unnecessary losses.

8.1.2 Structuring the benefits

Now all benefits have been discussed, the next step is to make certain offers out of these benefits. To do this the first step is to structure the benefits into a table. The following table gives an overview were benefits add value for the customer. The device feature and benefits are linked in this table.

Device features	Operations visibility	benefits generated to move towards operational excellence	Stakeholder
Location	Responsible stakeholder	<ul style="list-style-type: none"> • Lower insurance rates 	Consignee, Shipper
	Location information	<ul style="list-style-type: none"> • Reduce inventory 	Consignee, Shipper, Forwarder, Ship broker
	Lost prevention	<ul style="list-style-type: none"> • Lower insurance rate • Prevent value loss of cargo • Prevent unnecessary demurrage costs 	Consignee, Shipper
	Diversion monitoring	<ul style="list-style-type: none"> • Reduce the lead time of cargo • Prevent unnecessary demurrage costs 	Customs, Consignee
	Disruption identification	<ul style="list-style-type: none"> • Reduce the lead time of cargo 	Consignee, Shipper
	Improve the ETA's	<ul style="list-style-type: none"> • Reduce inventory • Prevent unnecessary demurrage costs 	Terminal, Consignee, Forwarder, Ship broker
Integrity	Container integrity	<ul style="list-style-type: none"> • Lower insurance rate • De-risk containers at Customs 	Customs, Consignee
	Theft prevention	<ul style="list-style-type: none"> • Lower insurance rate • Prevent costs of stolen cargo 	Consignee, Shipper, Forwarder
Sensor	Cargo conditioning	<ul style="list-style-type: none"> • Prevent value loss of cargo 	Consignee, Shipper
	Damage monitoring	<ul style="list-style-type: none"> • Prevent value loss of cargo • Timely action on loss of cargo during transit 	Consignee

Tab. 8: Value propositions framework

The usefulness of this table can be described in four advantages:

1. First the table combines the operational visibility with the actual cost or time savings. Although the operational visibility is a benefit on its own, it will only make an impression to customers when talking about actual cost or time savings.
2. Secondly this table shows which customers segments can possibly benefit from these operational visibility benefits.
3. Thirdly the table shows which information leads to these benefits. This is both useful for the customer as the provider. The customers will know which information leads to certain benefits and for the provider this is a way to see which device (technology) needs to be used to realize these benefits (this will be discussed in the next paragraph).
4. Finally this table introduces a framework which can be used for container tracking providers to organize and analyze the benefits. Although most of the benefits are implemented in this table, market and technology circumstances can cause this table to be outdated or incomplete. With the introduction of new technology, for example a new kind of sensor on the tracking devices, there can be additional benefits. This table allows providers to visualize this properly.

8.1.3 Benefits and the different devices

If certain offers are going to be made, the technology which is used is vital especially when looking from a provider’s point of view. Every device offers different information. In the table below the benefits are related to the device which is being used.

The table below shows an overview of the benefits and the hardware that can realize this benefit.

	eSeal	CTD	CTD with GPS	CTD with GPS and sensors
Responsible stakeholder	X	X	X	X
Location information	X	X	X	X
Loss prevention			X	X
Prevent diversion			X	X
Proactive monitoring			X	X
Improve the ETA's			X	X
Container integrity	X	X	X	X
Theft prevention		X	X	X
Cargo conditioning				X
Damage monitoring				X

Tab. 9: Devices and their benefits

A few remarks should be made for this table:

- **eSeal:**
 - The exact position of the container is unknown. The device knows where the container is because of the RFID reads. Therefore the exact position is not known, only when it passes certain checkpoints.

- Because the eSeal will break when the container is opened, all benefits will disappear. The benefits for the eSeal only occur when the tag is still working.
- **Container Tracking Device (CTD):**
 - The exact position of the container is unknown. The device knows where the container is because of the RFID reads. Therefore the exact position is not known, only when it passes certain checkpoints.
- **Container Tracking Device with GPS (CTD with GPS):**
 - If satellite communication is available the container can also be tracked on open water (when there is no GPRS coverage) and therefore the visibility of the journey will improve.
- **Container Tracking Device with GPS and sensors (CTD with GPS and sensors):**
 - If satellite communication is available the container can also be tracked on open water (when there is no GPRS coverage) and therefore the visibility of the journey will improve.
 - Sensor data can be sent during the transit on open sea. This way these signals can be timelier (when there is no GPRS coverage this information could be send out hours later).

Not all devices send the same amount of information because not all technology is implemented in the device. From the container tracking providers' point of view this information is useful to come up with certain offers. If customers only want to know certain information, the cheapest hardware solution should be used for it. From the customers point of view this table is giving them information about what benefits they can expect from certain devices.

8.1.4 Offers

After reviewing all the collected data mentioned above certain offer can be developed. When looking to the example of the SICIS system the value is created by giving container tracking and tracking information which is timely, accurate and complete. The actual valuable part is the information itself. A visualisation is made in the figure below:

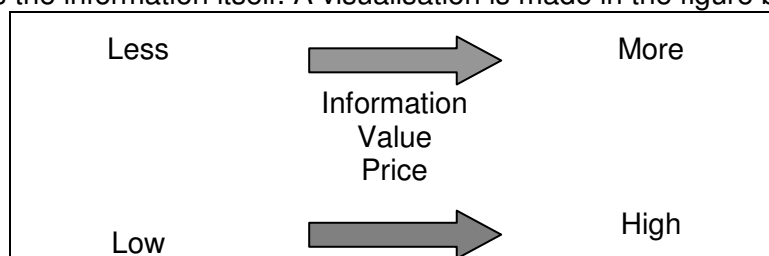

Fig. 68: Value of Tracking and Tracking information

The more useful information that is available for the customer, the more value it represents. From the container tracking service provider point of view the price of the service can rise according the amount of information which is being provided.

The developed offers are based on the amount of information they provide. A combination has been made between the technology and information in the table below to come up with certain offers:

	Basic visibility	Medium visibility	High visibility	Consultancy
Description	Basic container monitoring	Container monitoring during the journey	Container and cargo monitoring during the entire journey	Provide advice to create operational excellence of your Supply Chain
Reasoning	Use	Use	Use	Use
Life cycle	Value use	Value use	Value use	Value use
Value level	Innovative imitation	Innovative imitation	Innovative imitation	Excellence
Price level	Market	Market	Market	High end
Device used	eSeal or CTD	CTD with GPS	CTD with GPS and sensors	CTD with GPS (and sensors).

Tab. 10: Offers

Each offer provides different information and therefore represents different value for the customer. The benefits that derive from these offers are mentioned in Tab. 10. A combination has been made between the technology and information. This has been done for two reasons:

- Different devices provide different information. An eSeal can only provide certain information whereas a CTD with GPS and sensors is able to provide far more information.
- Different devices differ in costs. eSeals are cheap, CTD with GPS and sensors are expensive. The operational cost will therefore be higher. A CTD with GPS and sensors will also be able to provide the information which is needed for the basic visibility package, but it will be higher in costs.

Reasoning and life cycle

All the offers have the same reasoning and are in the same life cycle. When using this service the customer has the ability to get container/cargo information which can be utilized.

Value level

The visibility packages (basic, medium and high) have a value level described as an innovative imitator. The reason for this choice is the following: Currently container information is (limited) available. The major problem of this information is that it is not timely, accurate or complete. A container tracking service is able to give this information timely, accurate and complete.

The value of the consultancy package is excellence. With the information provided by the container tracking service a supply chain can be thoroughly analysed. By getting visibility about how containers are moving, customers can act accordingly to minimize time delays in any part of the journey and eventually save money.

Price level

The price levels of the different visibility packages have been market as market. The current economic situation does not allow the providers to setup their stakes to high. It will be difficult to get customers who want to invest in such a service at this moment and therefore the prices shouldn't scare them too much. If the provider is too expensive for them they will go to a competitor who can provide similar services for a cheaper price. The consultancy service is set to a price level of high end. In this study no company was found who provides such a service alongside the container tracking service itself. Because of the fact this consultancy service can lead to long term savings and operational excellence it is worth investing in.

Data providers

Another offer can be to only provide the data to customers. This is not explicitly mentioned in this offer because it is not in line with the goal of the Integrity project. The same packages can be offered, the only difference is that only the data will be offered to customers, not the information through an information system. The analyses of the data should be done by the customers own information system.

Offers and the Value of Tracking and Tracking information

These packages can be integrated with Fig. 68 to show how the positioning of the package is.

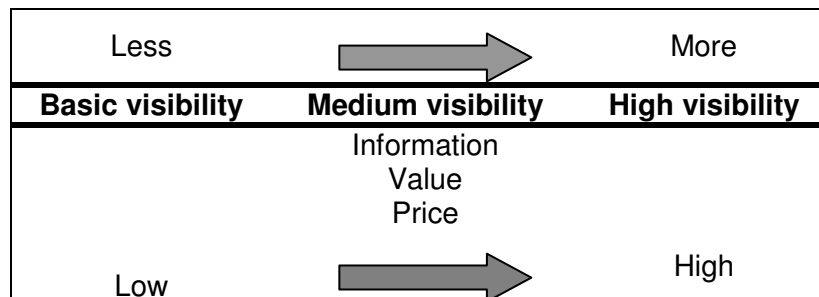

Fig. 69: Offers and the Value of Tracking and Tracking information

The more information is offered, the more value the information represents. The high visibility package offers more information than the basic visibility package and is therefore more valuable.

Choosing for a package with more information does not mean it will represent more value for every customer, this depends on what kind of information the customer is interested in.

8.1.5 Revenue Streams

The scope of this study does not cover the financial part of the business model (cost structure and revenue streams). The information gathered during the research period offers the opportunity to give some examples of cost savings derive from container tracking service.

To make certain costs savings visible a simple scenario is made about the transport of a container. In this example a container is shipped from Yantian (China) to Rotterdam (The Netherlands). The total costs of the journey are divided in individual costs to make certain costs, like the insure costs, visible.

These scenarios described are not taken from actual offers from a shipper. When importers ask for a fair to transport a container from one port to another, a total price is made; individual costs are taken into the total price. This scenario is based on information which could be found on the internet about container transport costs. The total price to ship a container from Yantian to Rotterdam was compared with public offers which could be found on the internet.

Although the scenarios mentioned are simple and incomplete, they can give insight in the possible costs savings when using container tracking services. The basic scenario shows the costs of the transport of one single container in normal operations. From this basic scenario two alternative scenarios are made. These scenarios show the costs of one single container as described in the following.

Scenario 1: Decrease of insurance rates

In the first scenario the insurance rates decreases. This benefit derives from the fact the entire journey is visible and this reduces risk for the insurance company. If the insurance rate decreases with 5%, the total costs savings with the transport of 5.000 containers will be €100.000,-.

Scenario 2: Prevent demurrage costs

Demurrage rates arise when a container is stored in the terminal at port of departure or port of arrival. The container waits until it will be loaded on the ship or picked up to continue to its final destination. Storing a container in the terminal is not free. The terminal usually has several “free days” which a container will be stored at the terminal for free. After these free days a demurrage fee is applied for every container per day this free period is exceeded. In scenario 2 an example is given when the container will stay at the terminal for three days after the free period on the departure and arriving port.

If this is the case for 10% of 5.000 containers the demurrage cost which are made are €48.000,-. The charges per container per day are not that high but with high volumes these charges will raise fast. The €48.000,- mentioned can all be saved by bringing the container to the terminal just in time and also picking up the container as soon as the ship arrives.

8.2 The Value propositions

In previous research about the benefits of container tracking services authors had difficulties to explain these benefits in a proper way and make them understandable for potential customers. Getting all these benefits together in an understandable way to make

viable value proposition was a challenge. Several options are presented to structure these benefits and useful frameworks were introduced for future usage.

To get a complete view of the results presented in chapter four all research questions will be briefly discussed.

Q 1: What are the transaction relations between stakeholders in a supply chain?

The studied literature describes how the transaction relations in supply chains are organized. With standard 'rules' as the incoterms these relations are already defined. Due to the complexity of supply chains, which can be seen as a network of companies, the relation between stakeholders is important. To make sure a container tracking device can be implemented, different companies have to work together.

Q 2: Who are the target customers of the container tracking service?

Due to the complexity of supply chain relations it is not easy to tell which stakeholders are able to add value from certain benefits. This is also highly dependent on the transaction relation in a certain transaction. This study was able to identify stakeholders/customer segments who are able to add value with the benefits but there might be others who can add value for their company with the same benefits. This should come forward when the eventual business model is tested/implemented and evaluated.

Q 3: What kind of capabilities (organizational and technical) are necessary to provide a container tracking service?

The main resource for a container tracking service is the devices themselves which are available as simple ones until very complex ones which can provide allot of information during the journey.

Not all of these resources are necessary to provide a tracking and tracing service. Providers can also choose to only offer an eSeal and only send the data. This way the provider only offers a very limited amount of services.

Q 4: What kind of information can be provided by the container tracking service?

The three vital means of data which are sent are the location, the integrity of the container and (if available) sensor data. These three data elements need to be processed by an information system where this data eventually becomes information. When this data is eventually processed the benefits will occur, the data itself has limited value on its own.

Q 5: What are the benefits of a container tracking service for the different stakeholders?

All the benefits that were found during this study are presented in Tab. 9. As seen in the table there are substantial benefits from the container tracking service. When the information of the service is used in a good way companies are able to save time and cost.

Q 6: How can a business model for a container tracking service help to develop a pricing strategy?

The price strategy of the interviewed container tracking service providers is discussed in chapter 8.5. When looking at the business model framework, and how it was used during

this study, it does not seem of any value for the development of a price strategy. Although, by dividing the business model in the nine building blocks it will give more insight of how a business model of a certain value proposition is build up. This information is also useful when developing a price strategy.

RQ: What are viable value propositions of a global container tracking service in a supply chain?

The main research question of this study is answered in chapter 6.4 where several value propositions are mentioned. Possible offers are presented of how these value propositions can be offered to the customers. The mentioned value propositions are written down in a way so these can be communicated to the customers in a way they understand. Current literature regarding these benefits is too difficult and with this deliverable this gap between scientific results and practical usage of this knowledge is reduced.

Research goal

The research goal was to create a method for the development of value propositions for a container tracking service. To create such a method a framework was build where benefits could be structured. The key of this framework is the simplicity. The framework is not difficult to understand and it gives the user insight in the benefits. When new technology arises, for example new sensors are developed, these can be added in the framework.

The development of such a framework is a creative process. The analyses of the value propositions according to the business model building blocks helped to understand how certain value propositions were created. This helped to eventually create this framework.

To verify the use of the framework it needs to be tested. This has not been done during this study and can be seen as a limitation.

Integrity project goal

In this study the project goal was to develop value propositions for a container tracking service. The intention of this deliverable is also to provide the Integrity project with useful information when a container tracking service is implemented in the SICIS system. In several chapters the link with SICIS is already mentioned and discussed. The offers can also be used in the SICIS context. Looking at the goal of SICIS: “significantly improve the reliability and predictability of door-to-door container chains” (INTEGRITY (2008b)), a container tracking service can be a part of the solution to reach this goal. A system like SICIS can combine the information from a container tracking service with the already present information available from other data sources which make the information in the SICIS system more valuable than the information from container tracing alone. This is a field where further research is necessary and to integrate the current research findings with (probably) more benefits from the system as a whole.

8.3 Current positioning of SICIS

Fig. 70 illustrates the current positioning of SICIS. At the moment SICIS is based on four sources of data:

- (1) Terminal data (HPH, DP World)

- (2) CSD integrity data (Savi, CIMC, LongSun)
- (3) Vessel tracking data (OHB/AIS, possibly to be extended with terrestrial data from Dirkzwager)
- (4) Cargo data (which can be uploaded as a PDF via a manual upload function)

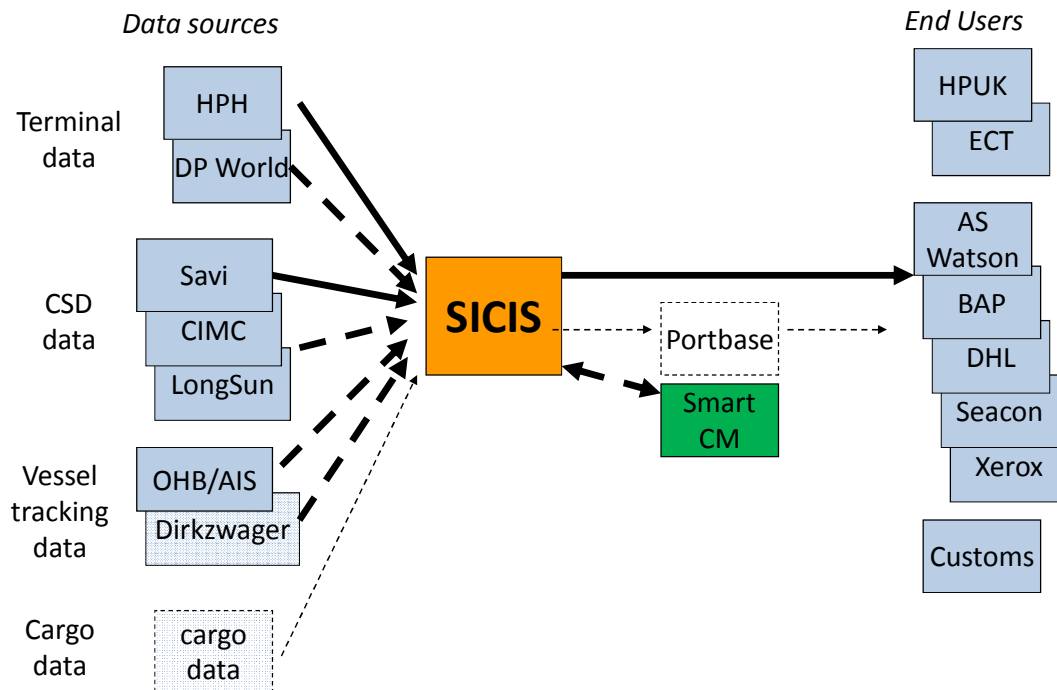

Fig. 70: Current positioning of SICIS

At the moment, SICIS services are directly used by four groups of end users:

- 1) Terminal operators
- 2) Logistics Service Providers (BAP, DHL, Seacon)
- 3) Shippers (AS Watson, Xerox)
- 4) Customs

8.4 Business Models for SICIS

For a system such as SICIS (i.e. a door-to-door container tracking platform which integrates data on parties, container integrity and cargo), there are four possible business model opportunities. These are labeled as follows:

- 1. Data

2. Information
3. Platform
4. Consultancy

8.4.1 Business Model 1: Data

The focus of the value proposition 'DATA' is the gathering of unique data in the platform. Currently, this data is: (1) terminal data on gate-in, loading, ship departed, ship arrived, unloading, gate-out; (2) begin journey at factory, end journey at warehouse; (3) ship tracking and (4) capture of general and specific cargo information. The key issue for this data is completeness. This is covered for the ship tracking, but needs to be arranged for factories and warehouses, and for terminals. For cargo data, the benefit is that declarations along the supply chain can be generated from a central source of data.

Further work in INTEGRITY on the completion of the data in SICIS is required for the eventual development of the business proposition. For the terminal data this requires the most work, since other terminal operators have to be involved in the project.

For the factory and warehouse data, a specific problems needs to be addressed. This is the situation that in some supply chains, goods can come from a multitude of factories. In all these factories, data capture has to be arranged in a very un-intrusive way. This can be done with hardware, or software, and the specifics need to be developed and tested in the course of the project.

If the data set is completed, then several opportunities exist to sell the data directly to other data re-sellers and users. These opportunities need to be explored in due course.

8.4.2 Business Model 2: Information

On the basis of the data in the SICIS system, further processing and combination of data can lead to 'INFORMATION' that can be sold to trade lane partners. Especially in combination with benchmark or reference data that represent expectations, this information emerges in the form of alerts, messages, warnings, which can be sent in various forms to users. Another dimension of this proposition is the integration of data from various sources in a trade lane. The main example is the integration of container integrity data with cargo or consignment data.

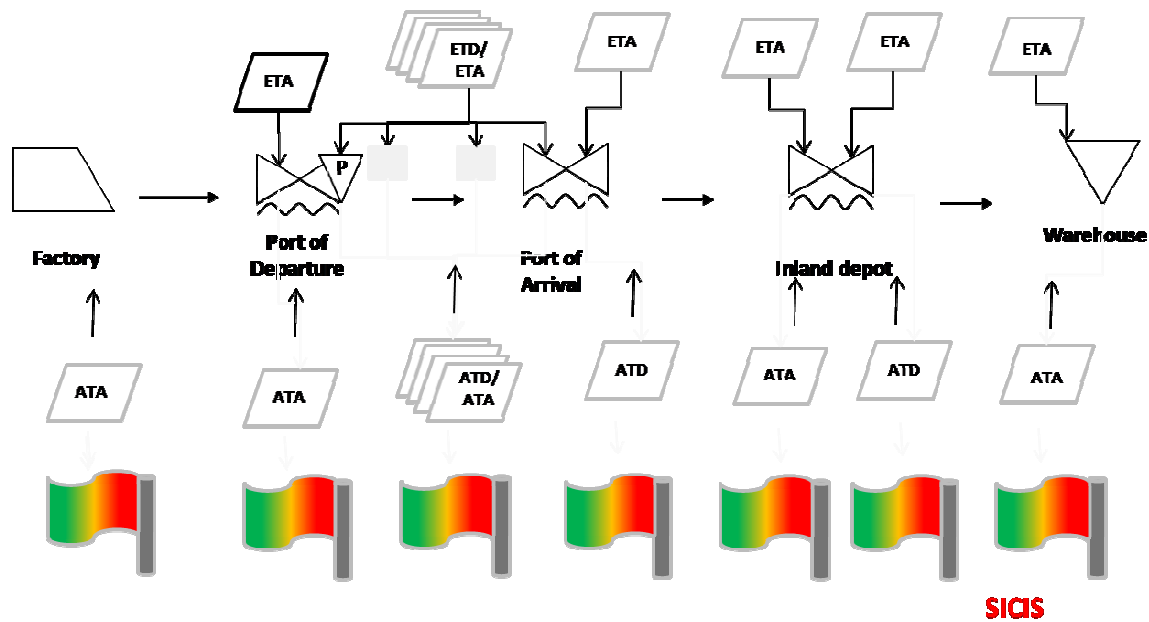

Fig. 71: Alerting service in SICIS

There are various problems and challenges with this part of the value proposition. First, there is the additional requirement of feeding the benchmark data into the system. This requires additional data capture solutions, either at the template level, or at the transaction (i.e. container) level. Second, information as a service package is difficult to define, and depends strongly on the specific needs of a trade lane community. This can lead to a situation that the information service package needs to be defined from scratch for every new (group of) customer(s). The standardization of the service package does not completely solve this, because customer groups can always demand some additional, or new, little service which then has to be offered to reel in the customer. Thirdly, specific services, such as alerting, can be bought in the market as ready products or applications that can be fit onto an existing data platform. This makes the development of that service from scratch unattractive. Finally, a trade lane community is a diverse group of parties, with different needs and expectations of visibility. It is not so easy to sell a single product in such a community. In fact, very little is known how marketing and sales work in diverse communities.

8.4.3 Business Model 3: Platform

Apart from the data and informational services, the SOA platform itself, with its embedded features such as the template definition, user access protocols, company registration, and unique interfaces and data sources can also be offered to the market as a service in itself. This means that an eco-system of third parties can develop their own applications on top of this platform in a commercial setting, like the Apple iPhone eco system.

One of the main conditions for this particular value proposition is that the platform is open and easily accessible for software developers. It should then preferably be hosted on an independent server that has no direct commercial connections with any of the partners in the INTEGRITY project.

8.4.4 Business Model 4: Consultancy

With an existing and proven visibility platform, there is an alternative to selling the services to trade lane partners. This is to use the platform for consultancy services in short to medium term products for companies, governments or supra-governmental organizations. The system itself is then used as analytical or monitoring tool that can be used to complete a set of tools and methods to analyze problems in trade lanes. Several of these other tools have been developed or used in the course of the INTEGRITY project, such as the supply chain templates and the stakeholder/transaction overview.

One concrete option is to approach large companies and sell the analysis of their supply chain network, based on analysis of past and/or future transaction data via the SICIS environment. Another option is to sell the tools, including the SICIS model, to international organizations such as World Bank, with the aim to analyze bottlenecks for trade and to provide a measuring tool for trade facilitation.

8.5 Charging structures for SICIS

The various possible business models as listed in chapter 8.4 imply different charging structures. Possible charging structures are listed in the table below.

	Customer	Pricing basis
DATA	GT Nexus, C Hawk, etc	Yearly fee
	Supply chain partner	Download fee
INFORMATION	Supply chain partner	Subscription basis and/or Pay per alert, declaration and/or correction
PLATFORM	IT service provider	Access fee to development platform
CONSULTANCY	world bank	Pay per hour Pay per use of the platform
	company	Fixed fee

Tab. 11: Business models and charging options

9 Revenue generation and exploitation scenarios

9.1 Generic exploitation scenarios

In general there are three possible scenarios for further exploitation of SICIS, as shown in Fig. 72.

The first scenario is an indirect model, where SICIS offers data, information/services and/or (access to the) platform to other existing platforms as users. This has two main benefits. First, there is no need to set up individual connections with large numbers of users. Second, SICIS can be integrated in existing platforms, which already have a large user group and deal with large volumes of containers (e.g. Portbase in Rotterdam annually handles about 3 million containers). This way economies of scale can lead to a low cost per unit.

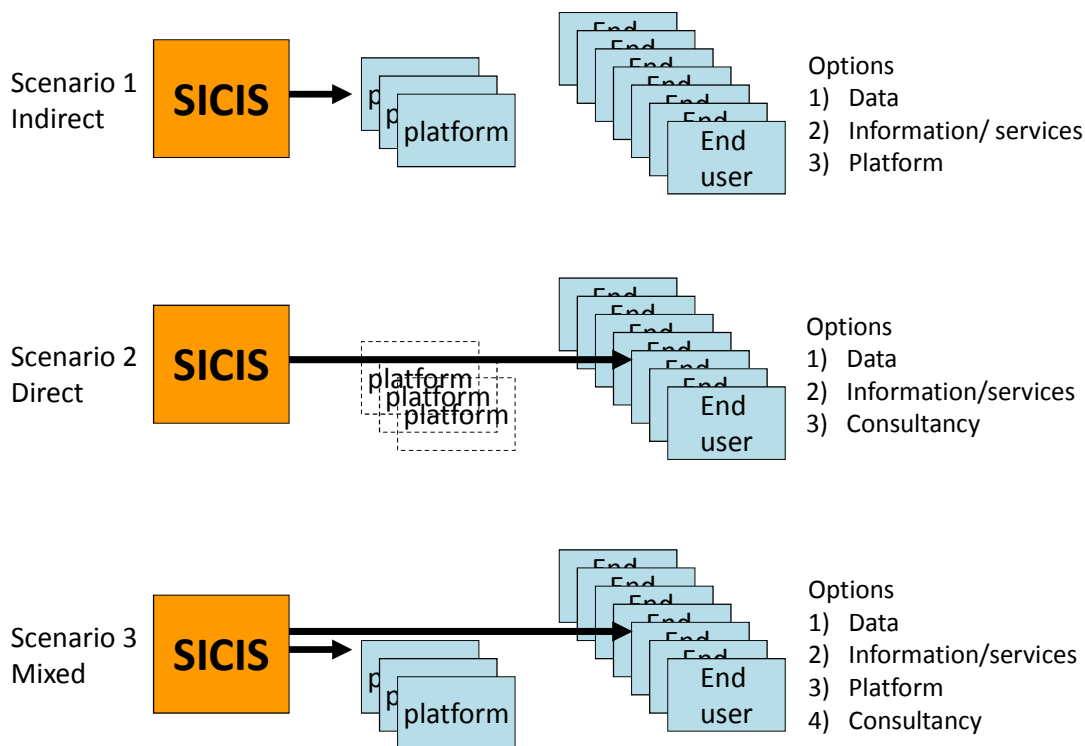

Fig. 72: Generic exploitation scenarios of SICIS

The second scenario is a direct model, where end users use data, information and/or consultancy directly from the SICIS platform. In the current situation this model has been implemented via a web interface and alerts (via SMS, mobile phone etc) to the end users.

The third scenario is a mixed model, which is based on a combination of direct usage and access to the SICIS platform and indirect access via other existing platforms. In this model end users can choose to use SICIS directly, or make use of the data and services via an existing platform, linked to SICIS.

The choice for a scenario will have implications for the further exploitation of SICIS and associated costs and charging structure.

9.2 Specific Exploitation scenarios

Currently, we foresee three possible exploitation scenarios.

9.2.1 Scenario 1: Continuation of SICIS services after the project and extension in further research

The first realistic option for the continuation of SICIS after INTEGRITY finishes in May 2011 is the continuation of the current services for the respective project partners. The key enabler for this is the continued running of the system without further development or commercialisation.

Assuming that the respective costs would need to be covered with the current flow of containers (say 5000 per year), the required contribution per container is about \$75-98/container. This does not include the costs for using container security devices (based on fixed running costs of \$380-490 000).

A more realistic fee for the type of information services provided by SICIS would be \$0,50-1.00 per container, given that many users are really interested in one or two milestones only. This means that a volume of 500.000 – 1.000.000 containers needs to be acquired to cover running costs (ignoring for the moment additional hardware costs required to handle the additional volume).

Clearly, there is no match between the current volume and the fixed costs of running the SICIS system. The current volume is simply too small to cover costs at realistic market prices.

There is a possibility to make this scenario work in practice and that is to keep the system running for use in a follow-up project. These projects would then bear the costs of running the system. Two projects have expressed an interest to use the system in the course of their projects.

9.2.2 Scenario 2: Providing SICIS as part of a port community service

SICIS can in principle be developed as a pipeline for container tracking data that contains information from the following sources:

- Data capture for start journey at factory or consolidation centre (via CSD, manual data entry or other solution),
- Data capture at container terminals
- Data capture of ships

This container tracking pipeline will enable the communication on milestones, the confirmation of shipment of containers by identified vessel, and the prediction and evaluation of ship eta in port.

This pipeline of information is a valuable addition to the current information available in any port community. Some of the envisaged data is already available (ship eta, terminal operations in port of unloading), but may not be readily accessible, or inaccurate.

As an information dissemination platform, a port community system that has established connections to the entire port community is the preferred solution. Alternatively, in cases

where the container terminal = the port, or the port has only one container terminals, the web platform of the container terminal operator might also be a suitable platform for information provision.

In a full commercialisation of this scenario, the aim should be to cover a large part of or the entire flow of containers to the port. In the case of Rotterdam, this constitutes about 3 million containers.

The financial calculation will look as follows – as shown in Fig. 73:

Fixed costs (per year), currently estimated at \$0,10 per container

Revenues, assuming a charge of \$ 0,35 per container.

This would mean a break-even with about 3.000.000 containers and a profit in case of more containers. This is in case the commercial risk is borne by ‘SICIS Ltd’. Alternatively, the risk could be borne by the port community system, which means that the revenue would be generated as one lump sum amount.

Discussions on this scenario are underway with potential partners in some Dutch and British ports. However, additional data and information requirements have surfaced that were not initially part of the scope of the SICIS development. This concerns mainly the forecast ability of container unloading times in port.

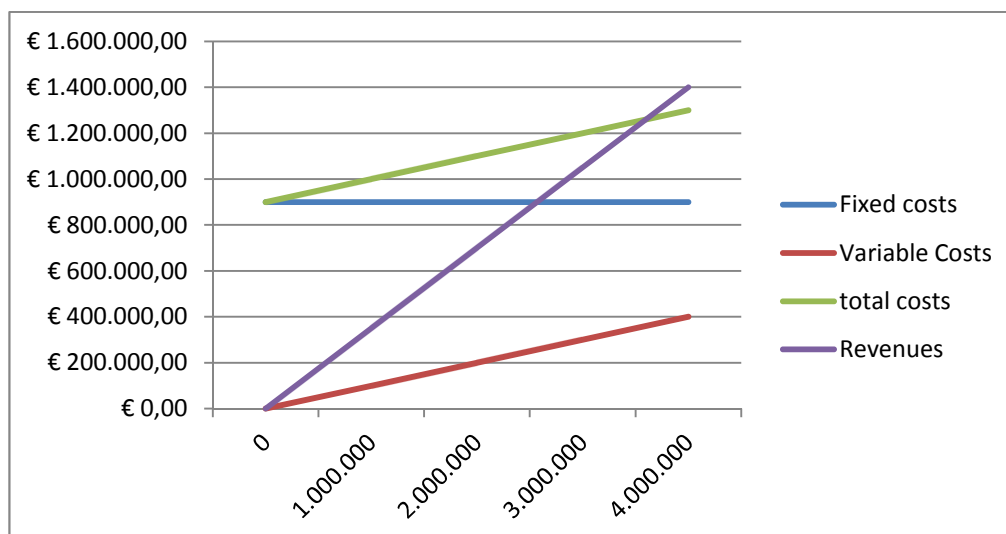

Fig. 73: Hypothetical exploitation scenario for SICIS

A requirement for this scenario to work in its most extended version is that all ports where cargo comes from are covered by the system. For large ports, this may mean that a large number of container terminals need to be covered, but for other ports, a selection of terminals may be more than sufficient to provide the required data for a large section of the flow. Furthermore, a more limited information possibility, where the information pipeline originates somewhere half way between the ports of origin and destination is also feasible. This means that no terminal information from ports of origin is required at all. This latter option is already feasible now with the functionalities of the SICIS system.

9.2.3 Scenario 3: Developing SICIS into a container terminal pooling platform

SICIS contains unique data on terminal operations. Currently, this only originates from the Hutchinson network of terminals. Provided all major terminals at both end of a supply chain are covered, this unique set of data covers more than 50% of the information requirements of supply chain owners. Another important information requirement is ship eta and eta reliability.

If, therefore, information on terminal operations at origin and destination could be combined with ship tracking data, a very powerful data source will emerge, that has several commercial applications. These include:

- Generic data pipeline provision to selected port community systems
- Data provision to existing visibility platforms
- Automation of data provision to carriers
- Data provision to selected global shippers and freight forwarders
- Data provision to government information systems such as Customs intelligence.

An important and crucial requirement for this scenario to become feasible is the integration of terminal data across various global terminal operators. These terminal operators would first need to establish their internal data pooling systems, which would then be pooled in second instance in SICIS. Within SICIS, the structure exists to pool selected containers, or to pool all existing containers and provide the data in an output channel.

The best strategy would be to start operations with a launching customer with a sufficiently large volume or information need that the basic system costs are covered. Revenue from additional customers would then constitute almost pure profit, since the set-up costs and variable costs of running this data pool are limited.

9.3 Exploitation strategy

In this chapter, we describe the concrete activities involving SICIS from June 2011 onwards. In practical terms, we have identified three paths from the business model options:

1. 'Information'
2. 'Consultancy'.
3. 'Data' (pipeline)

The activities in these three options are described below.

9.3.1 Information product development

Background: information delivery in and around ports will be changing drastically in the next five to ten years. This is partly due to the expected changes in the way Customs in Europe (especially the Netherlands and the UK) will be gathering their information in the development from MCC2013 to MCC2020, and partly due to other developments in

business community systems, software engineering through business applications which are made available in app-stores, and open data source development.

The Integrity consortium expects that information will increasingly be made available in the form of small information applications ('apps'), which can be hosted on any platform. The key to these apps is the access to good quality data. In addition, exploitation of data is one of the main ways for companies with high fixed investments in assets (such as container terminals) to generate additional revenues.

On the basis of the SICIS infrastructure, a first small information product called the 'ship arrival service' could be developed. This product is a first product of a number of information products that will all be delivered in a business app store.

The main features of the ship arrival information product are:

- Delivery of real time ship ETA, ETD, ATA, ATD
- Reception of triggers directly from customers' systems, delivery of information directly into customers' systems
- Charging per container, or as subscription per month, target price is €2/cntr.
- Focus on container collectors in sea ports as main customer group
- Use SICIS data integration, connectivity and company registration and template features

Recent research among freight forwarders¹⁹ shows that collection of data on ship and container arrival in port is done manually (by looking up information on shipping line, terminal and port community system websites). Potential savings from automating this activity range from €5-15 per container for freight forwarders. This does not include the economic benefit from lead-time reductions and visibility enhancements in the chain that accrue to shippers and consignees. The business model canvas for this product is based on the following components: Customer segments (CS); Value propositions (VP); Channels (CH); Customer relationships (CR); Revenue streams (R\$); Key resources (KR); Key activities (KA); Key partnerships (KP); Cost structures (C\$). The specification for the Ship Information Service is shown in Fig. 74.

¹⁹ FENEX/SYNTENS/RSM (2010).

The Business Model Canvas

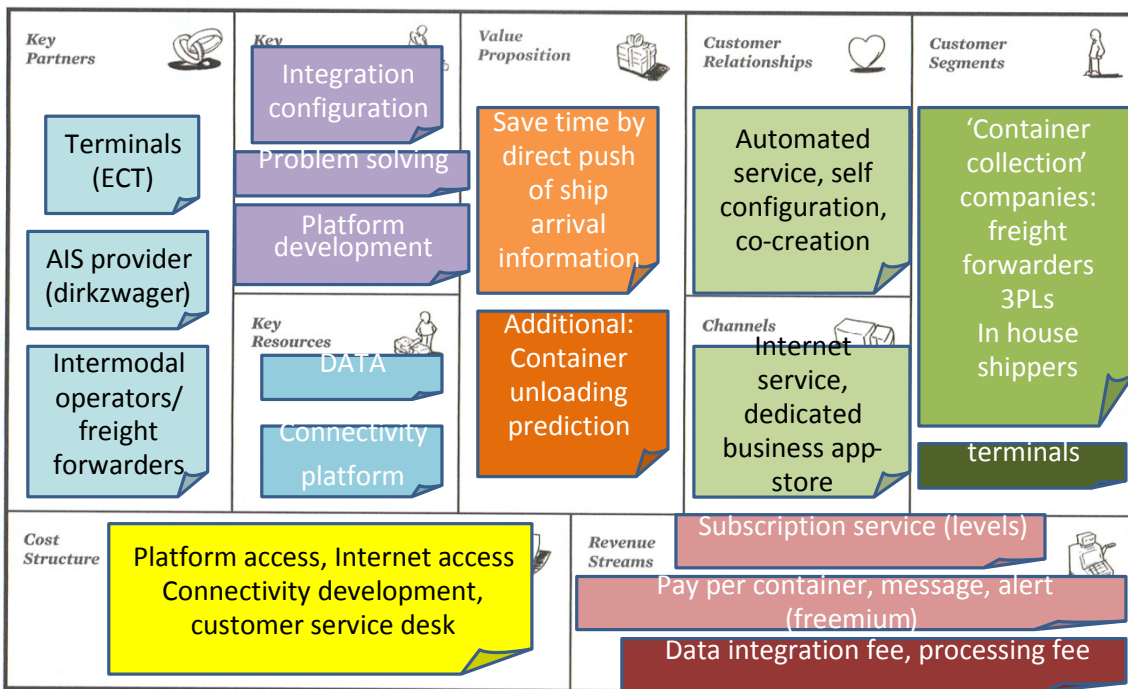

Fig. 74: Business model canvas Ship Information Service

Further development is possible, once this first product is being launched. One could envisage three avenues for additional product development or product enhancement:

1. offering an addition product containing container status milestones.
2. extending the ship arrival product with container unloading predictions. The basic research for this extension will be done in the Dutch Dinalog project ULTIMATE.
3. Further integration of ship arrival and container status information with destination and transport mode information from customers. This will lead to additional business models that may also require the valuation of terminal efficiency benefits.

9.3.2 Consultancy applications

Consultancy was identified as a business model option, in which the SICIS system would be used in projects that would require the functionalities SICIS can offer (easy connectivity, data integration, access to container terminal data). Several such projects have been identified and INTEGRITY partners have made arrangements to bring SICIS into these projects.

9.3.3 Data pipeline

One of the core parts of the vision of Customs is to develop a data pipeline creating more efficiency and effectiveness in the supply chain by using higher quality of information, making the information better available and integrating the different logistics layers. Consider SICIS as a ‘thin version’ (basic) of the data pipeline. Adding players like Port

Community Systems (PCS) would 'widen and lengthened' the pipeline by allowing rich *consignment cargo data* to feed into the pipeline. And then marry it with the milestones and projected vessel arrival, user authentication and container security status, the combined dataset can provide unique and comprehensive information to the customers of the Port Community System (PCS).

Talks among PCS in China and Europe about exploitation opportunities between Chinese PCS and EU PCS via SICIS as data pipeline have started since April 2011.

9.4 Customs use scenarios

In this chapter, we explore the use scenarios of the SICIS system for Customs supervision purposes. A brief summary of the key features for Customs are:

1. Customs requires container tracking data in combination with container content information
2. Customs requires a solution to suppress information provision during inspections.
3. Customs requires information capture from the earliest stage in the container chain as possible, preferable from the point of loading, closing and locking of the container.
4. Customs is interested in additional information on parties involved in the transportation of the container: 'true' consignor, 'true' consignee, security compliance status of all parties involved.

The following contains several scenarios for provision of data to Customs. These scenarios could roughly be termed: current situation (without ICS), current situation (with ICS), future situation (pipeline model), where ICS is the abbreviation for the EU Import Control System.

The main issue related to these Customs use scenarios is that they are not a business opportunity per se, since Customs will not pay for the additional data and businesses will be interested in the additional data services only if there is a clear (legal) requirement, or other quantifiable benefits. The identification of these benefits, but more importantly, the quantification of these benefits is not at all clear. Time savings in Customs procedures are, for most companies, negligible, and the selection for inspections or scanning occur so infrequently, and often due to random selection anyway, that any reduction is hardly possible. What possibilities there are explored below.

9.4.1 Current situation (without ICS)

In the current situation without ICS (Import Control System), Customs selects suspicious containers on the basis of an automated risk assessment approach (on the basis of information presented to Customs in declarations), removes as many un-suspicious containers from the risk list as possible (de-risking), clears all unlisted containers, and then plans the logistics for the remaining scanning and physical inspection activities.

Opportunity exists for SICIS to:

- provide better data for the declarations by feeding more accurate data into Customs declaration software used by the trading community,

- help de-risk containers by feeding data to the Customs risk assessment system or serving as an additional look-up system for Customs risk officers,
- and improve logistics planning of inspection activities by feeding data to the Customs planning system.

The main benefit of this scenario would be the possibility of pre-clearance of containers: based on the available information from the start of the container chain, and confirmation of the integrity of the chain during transit, the content of the container could be cleared by Customs before arrival of the vessel in the port of destination. In the Netherlands, this is being explored (also without the container tracking data), but as part of a broader streamlining of administrative processes related to Customs clearance.

9.4.2 Current situation with ICS

ICS adds to the previous scenario the submission of a preliminary declaration 24 hours before loading on board of the vessel. This submission is evaluated in the first European port of call, and a load/no-load decision is communicated to the sender, carrier and terminal in the port of origin. Submission of an ICS declaration leads to the registration of the consignment under a Movement Reference Number (MRN). For a proper communication with Customs about the consignment, this MRN should be connected with the container number. This connection is one of the functionalities that is provided in SmartCM.

Again, SICIS can play a role in providing the information for the new ICS declaration to any declaration system used by the members of the trading community.

Given that there is one more declaration, providing information to declaration system from a single source gains additional relevance. Reconciling information from different declarations and statements can take valuable time and effort from Customs agencies, and may lead to unnecessary delay of clearance. Based on this consideration, SICIS may gain a customer base of quality logistics service providers and freight forwarders.

For scenarios 1 and 2, an important step in the commercialisation is to initiate exploratory discussions with Customs declaration software providers.

9.4.3 Future situation

The 'future situation' is characterised by providing a data pipeline that can be accessed continuously by Customs. In the ideal situation, active search by Customs for information on consignments will replace declarations altogether.

Currently, SICIS provides elements that would fit in this scenario: SICIS is a continuous data pipeline that represents the container chain door-to-door. The data is continuously accessible for look-up.

However, SICIS does not provide original consignment information yet. Capturing consignment information, especially the provision of the data by the respective partners, is the main bottleneck for the development of the information pipeline that can be used by Customs. This issue will be addressed in more detail in a future FP7 project: CASSANDRA.

10 Vessel arrival prediction as a value added service

10.1 Introduction

Nowadays operators of transport chains are supported by Track & Trace systems, this means current information concerning monitored containers are displayed for one part of the chain. Several systems have to be checked and the comparison between planned data and actual information has to be done manually, which is a time consuming process. For the evaluation of the current status of a container in intermodal transports, the comparison between the expected time of arrival (ETA) and the current position of a container has to be done by operators for each mode of transport.

After the computation of the current status, deviations in the container transports are indicated rarely, but operators are only interested in case of problems. The reduction of useless OK messages could be achieved by systems where the operator is informed proactively only in case of deviations.

For the evaluation of the current situation of the container transport such a system has to be equipped with the ability to compare the planned data and the current events, like operators. The decision rules which are used by the operators have to be implemented in such an evaluation system, whereas the decision rules are adjustable to define the actions which have to be taken in case of deviations.

The inversion of notification to a proactive system where users are notified by a system in case of alerts or events is a concept which is used in Supply Chain Event Management methodology. As a result the planned data is compared with actual events and the user is informed proactively only in case of deviations.

For the comparison of planned data and actual events several rules have to be evaluated, in addition the rules in container transport are to some extent complex.

This chapter describes the approach of the Complex Rules Evaluator to solve these problems by applying the Supply Chain Event Management (SCEM) methodology and a rule based system.

10.2 The SCEM approach

The Supply Chain Event Management (SCEM) methodology for planning and monitoring supply chains is well known in the production industry. This chapter informs about the approach within the Complex Rules Evaluator how SCEM concepts can be used for intermodal container transports covering several sub-transports performed by different transport modes (e.g. imports using ocean shipping between China and Europe, rail transport into the hinterland, final distribution to the receiver by truck).

The intermodal transport of a container is accompanied by so-called events, which divide into two categories: On the one hand there are expected events such as loading and unloading messages. These and the sequence of their occurrence are clearly defined and can easily be monitored. The second class are events which occur unexpectedly and which may allude to problems such as delay messages or a notice indicating a technical defect.

While traditional systems for planning, tracking and tracing are passive, i.e. the user gets updated information only if he looks into the systems; the idea of SCEM systems is to play an active role. To this end, the planned logistics chains (e.g. in door-to-door transports) with expected events at expected times will be defined and matched against incoming event messages. Depending on the configuration, certain triggers will be fired

- either if expected events do not happen
- or other events occur which were not expected.

An SCEM system has to compare the expected events with the actual events and decide on appropriate actions, e.g. inform the user, here the manager of the intermodal transport chain, in case (and only in case) of problems. The manager of the transport chain is enabled to react in time on exceptions. Problems can be coped with soon after their occurrence and before they cause a severe impact to the transport process. Thus, an optimisation of the transport chains will become feasible.

In the course of the Integrity project, the Shared Intermodal Container Information System (SICIS) has been developed to support this SCEM approach, whereas in SICIS only direct comparisons between expected and occurred events are possible. On the other hand, in order to compute rules with complex structures, for example to execute an action if event A is on time but event B or C is missing; a designated component has to evaluate such rules.

The Complex Rules Evaluator is an external component which is used by SICIS for the evaluation of complex rules in order to notify SICIS to execute an appropriate action, where rules are defined by users.

10.3 Decision rules

As already mentioned, the intermodal transport of a container is accompanied by so-called events, which fall into two categories: On the one hand there are expected events such as loading and unloading messages. These and the sequence of their occurrence are clearly defined and can easily be monitored. On the other hand there are events which occur unexpectedly and which may allude to problems such as delay messages or a notice indicating a technical defect.

Expected and unexpected events are assigned to an object which is affected by the event, which is within SICIS a container or a vessel. Affected objects, expected events and occurred events are so-called facts, which are used in a rule in order to decide whether an action has to be invoked or not. If there are many restrictions more than one rule has to be defined, which leads to a tree structure. This structure is called a ruletree which is able to represent the dependencies of rules to each other and their actions which are invoked if the facts have the desired the status.

For most events there are decision rules which examine its accurately timed occurrence, delay or total absence. Depending on the result of these examinations, the rule tree is able to initiate appropriate actions in a flexible way.

The definition of the rule tree is mainly oriented at the chronological sequence of the events' occurrence during the transport. Of course, there exist events with an undefined sequence with respect to each other. In addition, there are events which may occur at any

arbitrary point of time during the transport. The latter are related to unforeseen events, as for example damage may occur and be reported at any time. Of course, the latter events play an important role because they crucially affect the transport.

Consequently, there is a very complex set of decision rules which make up such a system. It is an important advantage of ruletree systems to provide the possibility of modelling the appropriate business logic in a very flexible way. In addition, the clear and concise graphical illustration of the decision rules makes the set-up and maintenance of Complex Rules Evaluator very easy.

The facts which have to be examined are read from a central database. The communication between the Complex Rules Evaluator and the database is performed by an appropriate software tool using the object/relational framework “Hibernate” to access the database which reads out the container/vessel data and the related events and passes them over to the rule tree which processes these data.

The actions which are invoked if a rule is fulfilled are defined in the Complex Rules Evaluator as Java method calls. Consequently, any Java source code can be defined as an action, whereas some standard actions are already predefined. For example, a predefined action which sends an email or a SMS can be modelled in the ruletree, whereas the user just has to define the recipients and the message. Beside this standard actions further user-specific actions can be defined for example in order to perform web service call to the system of the user which would be affected such that the appropriate voyage is cancelled and the containers originally associated to the cancelled voyage should be marked such that they can easily be re-scheduled to another voyage.

10.4 Vessel Arrival Prediction

In the course of the INTEGRITY project, the Shared Intermodal Container Information System (SICIS) has been developed to support this SCEM approach, whereas in SICIS only direct comparisons between expected and occurred events are possible. On the other hand, in order to compute rules with complex structures, for example to execute an action if event A is on time but event B or C is missing; a designated component has to evaluate such rules.

The Complex Rules Evaluator is this external component which is used by SICIS for the evaluation of complex rules in order to notify SICIS to execute an appropriate action, where rules are defined by users.

The application Vessel Arrival Predictor is a system which is using the Complex Rules Evaluator. The Vessel Arrival Predictor assists to detect future delays by comparing the vessels schedule to the current event times (terminal in and terminal out). If a vessel arrives the terminal x hours later, it can be expected that it leaves the terminal x hours later, too. Thus, the vessel will probably arrive the next terminal later than scheduled, and so on. Of course, the precision of the prediction to the next terminal is dependent on the distance in hours to the next terminal.

In order to predict the arrival time of vessels the rule engine is used to evaluate possible future delays by following the rules the user has defined.

To sum up, the rule engine is a powerful tool to precisely customize the behaviour of the Vessel Arrival Prediction.

10.4.1 Demonstration Results

The *Vessel Arrival Prediction* was tested using the vessel information coming from the SICIS system. Beneath that an average service speed had to be defined for each vessel, based on the vessel dependent information found on the websites of “marinetraffic.com”.

The related vessel schedules were grabbed from the websites of Hyundai Merchant Marine (“hmm21.com”), Maersk Line (“maerskline.com”) and Oceanschedules (“oceanschedules.com”). The best quality of schedule data was found on the Hyundai websites, also for vessels which were not owned by Hyundai (see example in Fig. 75).

	CODE	VOY	sails Hakata	Kwangyang	Pusan	Shanghai	Kaohsiung	Hong Kong	Yantian	Singapore	arrives Rotterdam	Antwerp*	Hamburg	Thamesport	
aex westbound	Hyundai Force	HHFC	013W	26-Mar	27-Mar	29-Mar	31-Mar	02-Apr	03-Apr	04-Apr	08-Apr	25-Apr	29-Apr	28-Apr	01-May
	Hyundai Brave	HHBV	019W	02-Apr	03-Apr	05-Apr	07-Apr	09-Apr	10-Apr	11-Apr	15-Apr	02-May	06-May	05-May	08-May
	Hyundai Navarino	HNVR	002W	09-Apr	10-Apr	12-Apr	14-Apr	16-Apr	17-Apr	18-Apr	22-Apr	09-May	13-May	12-May	15-May
	Hyundai Mercury	HHMC	013W	16-Apr	17-Apr	19-Apr	21-Apr	23-Apr	24-Apr	25-Apr	29-Apr	16-May	20-May	19-May	22-May
	Hyundai Courage	HHCR	015W	23-Apr	24-Apr	26-Apr	28-Apr	30-Apr	01-May	02-May	06-May	23-May	27-May	26-May	29-May
	Hyundai Loyalty	HHRY	013W	30-Apr	01-May	03-May	05-May	07-May	08-May	09-May	13-May	30-May	03-Jun	02-Jun	05-Jun
	Hyundai Global	HHGB	012W	07-May	08-May	10-May	12-May	14-May	15-May	16-May	20-May	06-Jun	10-Jun	09-Jun	12-Jun
	Hyundai Bangkok	HHBN	022W	14-May	15-May	17-May	19-May	21-May	22-May	23-May	27-May	13-Jun	17-Jun	16-Jun	19-Jun
	Hyundai Faith	HHFA	018W	21-May	22-May	24-May	26-May	28-May	29-May	30-May	03-Jun	20-Jun	24-Jun	23-Jun	26-Jun
	Hyundai Splendor	HHSL	013W	28-May	29-May	31-May	02-Jun	04-Jun	05-Jun	06-Jun	10-Jun	27-Jun	01-Jul	30-Jun	03-Jul
	Hyundai Force	HHFC	014W	04-Jun	05-Jun	07-Jun	09-Jun	11-Jun	12-Jun	13-Jun	17-Jun	04-Jul	08-Jul	07-Jul	10-Jul
	Hyundai Brave	HHBV	020W	11-Jun	12-Jun	14-Jun	16-Jun	18-Jun	19-Jun	20-Jun	24-Jun	11-Jul	15-Jul	14-Jul	17-Jul
	Hyundai Navarino	HNVR	003W	18-Jun	19-Jun	21-Jun	23-Jun	25-Jun	26-Jun	27-Jun	01-Jul	18-Jul	22-Jul	21-Jul	24-Jul
	Hyundai Mercury	HHMC	014W	25-Jun	26-Jun	28-Jun	30-Jun	02-Jul	03-Jul	04-Jul	08-Jul	25-Jul	29-Jul	28-Jul	31-Jul
	Hyundai Courage	HHCR	016W	02-Jul	03-Jul	05-Jul	07-Jul	09-Jul	10-Jul	11-Jul	15-Jul	01-Aug	05-Aug	04-Aug	07-Aug
	Hyundai Loyalty	HHRY	014W	09-Jul	10-Jul	12-Jul	14-Jul	16-Jul	17-Jul	18-Jul	22-Jul	08-Aug	12-Aug	11-Aug	14-Aug
	Hyundai Global	HHGB	013W	16-Jul	17-Jul	19-Jul	21-Jul	23-Jul	24-Jul	25-Jul	29-Jul	15-Aug	19-Aug	18-Aug	21-Aug

Fig. 75: Vessel schedule provided by Hyundai

To determine the demonstration results, some voyages of interest were selected at the beginning of the demonstration phase and the related data of the *Vessel Arrival Prediction* was archived (see example in Fig. 76).

Vessel									
UN-Number:	9393319								
Vessel Name:	HYUNDAI LOYALTY								
Call-Sign:	2BRH2								
MMSI-Number:	235068652								
Status:	OK_ON_TIME								
Monitored:	true								
<input type="button" value="Done"/>									

Schedules									
Voyage Number	#	Location	Distance	Planned Arrival	Predicted Arrival	Actual Arrival	Planned Departure	Predicted Departure	Actual Departure
013W	0	Hong Kong (HKHKG)		08.05.2011 00:00		08.05.2011 17:00	09.05.2011 00:00		09.05.2011 20:12
013W	1	Yantian (CNYTN)	46	09.05.2011 00:00		10.05.2011 00:06	09.05.2011 00:00		10.05.2011 09:30
013W	2	Singapore (SGSIN)	1436	13.05.2011 00:00	13.05.2011 05:52		14.05.2011 00:00	14.05.2011 05:31	
013W	3	El Suweis (= Suez) (EGSUZ)	4933	23.05.2011 00:00	24.05.2011 00:25		24.05.2011 00:00	25.05.2011 00:03	
013W	4	Rotterdam (NLRTM)	3345	30.05.2011 00:00	31.05.2011 15:20		01.06.2011 00:00	01.06.2011 14:59	
013W	5	Hamburg (DEHAM)	305	02.06.2011 00:00	02.06.2011 05:30		04.06.2011 00:00	03.06.2011 05:08	
013W	6	Thamesport (GBTHP)	398	05.06.2011 00:00	04.06.2011 00:05		07.06.2011 00:00	04.06.2011 23:44	

Fig. 76: Example of an archived Vessel Arrival Prediction

After the voyages had been finished the actual arrival times were available (see example in Fig. 77) and could be compared with the predicted ones to show the quality of the *Vessel Arrival Prediction*.

Vessel									
UN-Number:	9393319								
Vessel Name:	HYUNDAI LOYALTY								
Call-Sign:	2BRH2								
MMSI-Number:	235068652								
Status:	OK_ON_TIME								
Monitored:	false								
<input type="button" value="Done"/>									

Schedules									
Voyage Number	#	Location	Distance	Planned Arrival	Predicted Arrival	Actual Arrival	Planned Departure	Predicted Departure	Actual Departure
013W	0	Hong Kong (HKHKG)		08.05.2011 00:00		08.05.2011 17:00	09.05.2011 00:00		09.05.2011 20:12
013W	1	Yantian (CNYTN)	46	09.05.2011 00:00		10.05.2011 00:06	09.05.2011 00:00		10.05.2011 09:30
013W	2	Singapore (SGSIN)	1436	13.05.2011 00:00		13.05.2011 07:50	14.05.2011 00:00		14.05.2011 03:10
013W	3	El Suweis (= Suez) (EGSUZ)	4933	23.05.2011 00:00		23.05.2011 23:40	24.05.2011 00:00		24.05.2011 17:05
013W	4	Rotterdam (NLRTM)	3345	30.05.2011 00:00		31.05.2011 13:04	01.06.2011 00:00		01.06.2011 10:00
013W	5	Hamburg (DEHAM)	305	02.06.2011 00:00		02.06.2011 11:00	04.06.2011 00:00		04.06.2011 13:00
013W	6	Thamesport (GBTHP)	398	05.06.2011 00:00		05.06.2011 11:00	07.06.2011 00:00		07.06.2011 00:30

Fig. 77: Example of actual arrival times

To get a statement how precise the *Vessel Arrival Prediction* was, it was required to compare the planned schedule of the ship owner with the actual times, and also the predicted values with the actual times. Comparing the calculated deviation between the planned- and the actual-time with the calculated deviation between the predicted- and the actual-time, it is possible to show the quality of the vessel arrival prediction. To compensate the missing time value of the planned arrivals, it was required to use a default time value around midday (12:00) in the calculations. The comparison of the example above is shown in Fig. 78.

Location	Planned Arrival	Predicted Arrival	Actual Arrival	Deviation		Prediction better?
				Planned-Actual	Predicted-Actual	
Singapore (SGSIN)	13.05.2011	13.05.2011 05:52	13.05.2011 07:50	0,173611111	0,081944444	TRUE
Suez (EGSUZ)	23.05.2011	24.05.2011 00:25	23.05.2011 23:40	0,486111111	0,03125	TRUE
Rotterdam (NLRTM)	30.05.2011	31.05.2011 15:20	31.05.2011 13:04	1,044444444	0,094444444	TRUE
Hamburg (DEHAM)	02.06.2011	02.06.2011 05:30	02.06.2011 17:00	0,208333333	0,479166667	FALSE
Thamport (GBTHP)	05.06.2011	04.06.2011 00:05	05.06.2011 11:00	0,041666667	1,454861111	FALSE

Fig. 78: Comparison for Hyundai Loyalty

Looking at the example above the *Vessel Arrival Prediction* was really near to the reality, so that three out of five predictions were better than the schedules provided by the ship owner. But that success is not always possible. Comparing the predictions of all captured voyages with the actual arrival times, it can be said that the *Vessel Arrival Prediction* is around 35% more precise against the schedules provided by the ship owners. This increase of precision seems not that much, but there are some reasons that makes it very important:

- The schedules provided by the ship owners only specify the arrival date, without time value. So the precision of these schedules is very rough.
- The predicted arrivals also specify an estimated arrival time, so it's more precise than the original schedules.
- The increase of precision was calculated across a large part of the transport chain. But the Vessel Arrival System is a real-time system, which means: The closer the vessel gets to its destination, the more precise the prediction will be.

The result of the Vessel Arrival Prediction was send to SICIS every time when an arrival or departure event occurred for a voyage or when the voyage schedule had been changed by the ship owner.

10.4.2 Gaps in the current system

During the test period some gaps in the *Vessel Arrival Prediction* could be identified, and solutions were found to increase the quality of the predicted arrival times. These are described in the following:

The usage of an average idle time in the ports

The usage of an average idle time in the ports does not reflect the reality. While in large ports like "Hong Kong", "Rotterdam", "Hamburg", "Le Havre" a huge amount of containers will be loaded/discharge, the amount of containers handled in small ports like "Yiantian", "Ba Ria", "Suez", "Tangier" is much smaller. That's the reason why the usage of an average idle time for the ports produces currently the biggest deviations in the Vessel Arrival Prediction. While the average idle time in the ports of interest was calculated around 23.64 hours, the real idle time in our examples varies between 12.25 and 40.1 hours. Especially the early stops in the smaller ports lead to bigger shifts in the predicted arrival times.

A promising approach to solve this problem is the statistical analysis of the received vessel events. So it is possible to calculate the time between the arrival and departure of a vessel in a port. The statistical values should be determined over at least five

arrival/departure event-pairs per port and vessel. So it is possible to get a nearly realistic idle time for a specific vessel in a specific port, which should override the default values used currently.

The usage of an average service speed

The usage of an average service speed per vessel does not consider the different transport sections of a voyage schedule. So there may be variations in some sections where the vessel is faster or slower than the average. Especially on sea a vessel could use a much higher service speed than near the coast, which leads to some bigger deviations for the ports “Rotterdam”, “Hamburg”, “Thamesport” and “Le Havre”.

To solve this problem, the statistical analysis of the received vessel events will help again. In this case it is required to calculate the time between the departure of a vessel in the loading port and the arrival of the vessel in the discharge port. These statistical values should also be determined over at least five departure/arrival event-pairs per port pair and vessel. This information defines the average transit time of that vessel on that relation and builds the basis for the calculation of the average service speed between this port-pair. Also these statistical values should override the default values of the current *Vessel Arrival Prediction*.

Poor quality of schedule data

In some cases the schedule data requested on the internet had a very poor quality, so that the vessel arrival prediction was based on wrong information. A variety of this point is the fact, that vessels sometimes use a different route in the reality than defined in the schedule (e.g. skip ports with little container movements).

This kind of problem can only be solved by manual intervention. If the operator of the *Vessel Arrival Prediction* system noticed that a received schedule is not as usual, it is required to make some research and to change that schedule manually. A manual input requires some extensions of the software, so that an extra editor for vessel information must be realized. It is also required to put a flag on these manually edited schedules, to avoid them from being overwritten by the automatic update service.

Missing schedule data

Sometimes there were no schedules available for a given voyage, so that the *Vessel Arrival Prediction* was not possible.

This kind of problem requires a manual intervention like above, so that the solution is the same as under 0.

Poor quality of distance information

The distance information available is not that reliable as it should be. During the look on different sources for vessel distances, it was noticed that requests for the same relation leads to different distance results. So it is required to have a reliable distance base.

Another cause for deviations is the usage of one distance value per port pair, for all kinds of vessels. Depending on the relation, a Panamax sized vessel may have to negotiate another distance than a PostPanamax vessel, which may use another route than a Capsized vessel.

These problems can be solved again by using statistical analysis of the received vessel events and vessel positions. Like the solution in point 0 it is required to calculate the time between the departure of a vessel in the loading port and the arrival of the vessel in the discharge port. The calculated average transit time should be used in the *Vessel Arrival Prediction*, so that a calculation based on the average service speed and distance is not required. Also the distance itself can be calculated in a statistical way, from the vessel positions recorded between the departure- and the arrival-event.

Missing distance information

Sometimes there was no distance information available for a specific transport section of the schedule, so that a vessel arrival prediction was not possible for that section.

One possibility to solve this problem is the statistical analysis described under point 0. But, if statistical information is not available, manual intervention is required. In most of these cases, it was possible to get these values manually from other sources on the internet. So, if the operator of the system noticed that distance information is missing, it is required to make some research and to enter this information manually. Therefore an extra editor for distance information must be realized.

10.5 Conclusion of the vessel arrival prediction

In general we could show that the results of the Vessel Arrival Prediction were better than the schedule data provided by the ship-owners. But to make it a reliable system it is required to add statistical analysis, so that the identified gaps will be closed. These statistical analysis has to be vessel specific and should make a difference between

- location based information, and
- relation based information.

Location based information per vessel are:

- The average idle time in the port
- The earliest arrival in the port
- The latest departure in the port

Relation based information per vessel are:

- The average service speed between two locations
- The average driven distance between two locations
- The average transit time between two locations

The statistical information should be raised if a desired vessel made at least five voyages on the same relation. Using these statistical data, the Vessel Arrival Prediction is able to do its calculations very close to the reality.

There will be still some gaps that can't be solved, e.g. what to do if schedule information is not available. But this kind has a total different quality and can be solved by entering the required information manually.

11 Clustering with the SmartCM project

Cooperation with SmartCM was a continuing task from the very beginning of INTEGRITY, resulting in several joint meetings and workshops. In autumn 2010, a concept for the joint demonstration exchanging CSD information between the SmartCM Neutral layer and SICIS have been prepared, implemented and tested.

Unfortunately, the withdrawal of Savi Networks (being the INTEGRITY supplier of CSDs) from the market from Nov. 1st, 2010, caused a major drawback for these plans. Since the follow-up with the Chinese CSD provider CIMC starting demonstrations from mid of March 2011, this demonstration can be performed in March/April. Since already integration tests with CIMC devices and SICIS have been successfully executed before, no additional delays for technical problems are expected.

11.1 Interoperability

The basic concept allows for Web Services to be provided on both platforms (INTEGRITY and SmartCM). The following then applies:

- The Web Services provided by the other party are consumed by each application.
- Naming conventions were agreed between the two parties.
- Data content to be returned by the Web Services were agreed.
- Error handling were agreed to provide a standard mechanism across the Web Services provided.
- Each system provides a web service which allows user information to be registered across the systems (i.e. INTEGRITY is able to register a user on the SmartCM system and vice-versa).
- A way of handling data ownership and permission was agreed. The proposal is that the calling system will provide, as part of the XML message, the originating party asking for the information. The system containing the data will only pass this information back if the originating party has the necessary permissions. Therefore data permissions will always be handled by the system holding the data.
- There are two types of Web Service; one to “pull” data from the other system and one to “push” data to the other system. For example:
 - The “pull” service is used to obtain the current status of a consignment/container etc. on demand.
 - The “push” service sends an alert to the other system when a particular status on a consignment changes. In order to achieve this both systems maintain a “watch list” of containers/consignments in which the other system is interested. There is, therefore, a service on both systems to allow this “watch list” to be maintained (i.e. add a container/consignment to the “watch list”, remove a container/consignment from the “watch list”, etc.). A container/consignment will be removed from the “watch list” after a pre-defined time of inaction.

- A method of referencing containers/consignments will be agreed. This will include the use of a UCR (Unique Consignment Reference). Work already undertaken in this area (by Customs) will be investigated and utilised unless considered impractical.

It is proposed that the mechanism for interoperability is based upon SOA (Service Orientated Architecture). This will provide an open and proven method for creating and consuming services on both systems.

In addition as regards the various CSD technology providers these have different procedures and functionalities, while their message format and event types also differ. These various external event type codes are translated to uniform event types in the neutral layer of SmartCM.

These are:

- CSD Activation
- CSD Update
- Opening during transport
- Breach
- Close
- CSD Deactivation

The status events can be used as uniform and technology independent status events in the transport chain.

The access and distribution of the data were subject to the agreement of the industrial partners of the two projects. For the purposes of interoperability, specific Use Cases for the common demonstrators between the two projects were agreed.

Error handling was agreed to provide a standard mechanism across the Web Services provided. Error handling is related to system “errors”. The usage of Enterprise XML schema for Exception Messages can fulfill error codes for business (i.e. unreachable information, unauthorized access) and system error messages as well. Business exceptions are shown to the user with the appropriate descriptions and help. System errors are exchanged across platforms using an alternative channel (if the web service is down, the message cannot be delivered) and in a common agreement on administration process for diagnosis, and recovery scenarios.

11.2 Common Evaluation Criteria

The joint demonstration of INTEGRITY and SmartCM was evaluated. In order to achieve this, a set of common evaluation criteria was developed, which is described in the following. The results of the common evaluation was used to develop and refine the exploitation route and business model for the SICIS platform and the SmartCM platform. The evaluation needs to provide insight into the following aspects that influence the business model:

- adoption factors that influence adoption intention and use;

- main direct and indirect benefits;
- quality of system and information features;
- usage preference (direct access/use or indirect, via another platform.)

The results of the evaluation of SmartCM were be used for the Neutral organisation business model and the cost models to be used. This was based on determining and attempting to quantify the various benefits resulting from the SmartCM implementation, and the potential users' level of satisfaction and willingness to adopt.

11.3 Limitations and reflection

As with any evaluation there are a number of limitations. The question is to what extent the two systems (SICIS and SmartCM) are comparable. The systems have been developed from a different background and with a different approach. Therefore, the results of this study should be interpreted with these differences in mind. The evaluation will not be about deciding which system is better.

The measurements will be used:

- to improve each platform
- to work on interoperability among the platforms
- to learn about (potential) barriers in the adoption and use and
- to develop a feasible exploitation path and business model.

Due to the use of an interim evaluation, a large part of the evaluation outcome can still be used within the course of the current project. The remaining outcome of the evaluations will be used as recommendations towards follow up and input for next steps after the EU project has been finished in 2011.

11.4 Joint Demonstration with SmartCM

The concept of the trial was described in Integrity Deliverable 4.3 and provides more detail on the planning, system changes and interfacing for the trials. In brief, it was found that Integrity had developed functionality for container tracking through Container Terminal messages and vessel tracking through AIS and SMARTCM had developed Customs IES functionality with the only common area of functionality between them being the processing of Container Security Device (CSD) messages.

It was therefore agreed to confine the Interoperability to the exchange of CSD data as shown in the diagram below.

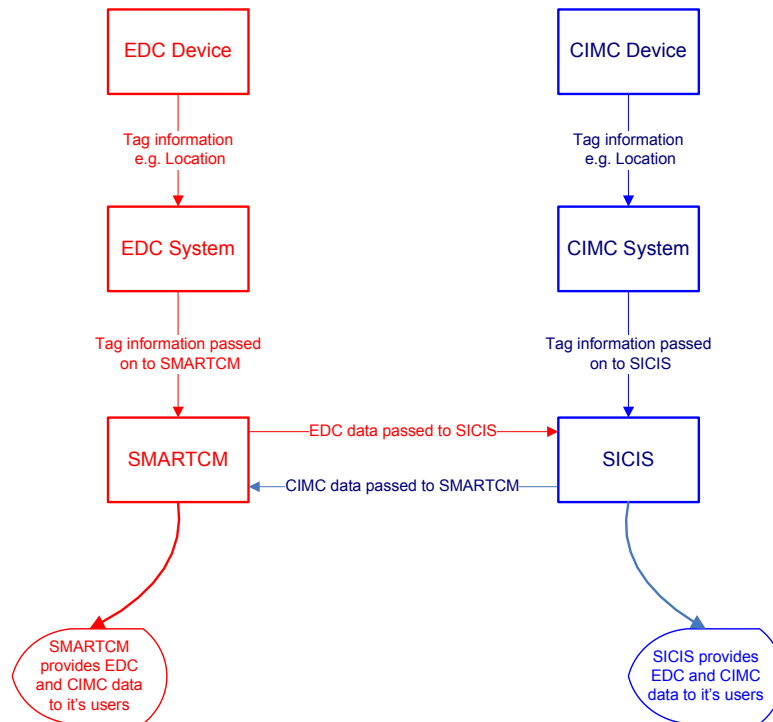

Fig. 79: Data flows during joint demonstration

Although the trial was limited to the exchange of CSD data it is actually demonstrating a more important point i.e. that users of one platform or system could still receive information about events which are being monitored by another platform.

The trial was scheduled for September 2010 but Savi Networks, the CSD supplier that Integrity intended to use for the trials, went into liquidation shortly before this. Integrity entered into discussions with its other CSD suppliers, CIMC and LongSun to find a replacement device. At that time the CIMC device provided the closest fit to the requirement for the trials but it did not have any GPS (Global Positioning System) capability, nor did it have 'global roaming' or 'GPRS' for the SIM cards fitted to its devices.

CIMC undertook a process of rapid development undertaking to supply a device with GPS and GPRS by March 2011. The trials were, therefore, rescheduled and successfully performed in April 2011.

11.4.1 Tradelane

DHL are a partner in Integrity and SmartCM and were a natural choice to provide the tradelane and containers for the trial. DHL offered a tradelane from Hong Kong to Antwerp via Rotterdam with a flow of two to three containers per week. This had the advantages of being completely new to both projects, it would exploit Integrity's ability to obtain Terminal Data from both Hong Kong and Rotterdam and the CSD would provide tracking information and report arrival in Antwerp.

For the trial CSDs from both CIMC (INTEGRITY) and EDC (SmartCM) were attached to the containers.

11.4.2 CSD Performance

Both the CIMC and EDC devices gave problems. In both cases their devices were attached to containers but failed to initialise properly either due to technical problems or operator failure. The latter was resolved for subsequent containers by additional training but the outcome was that messages were not sent by the devices.

CIMC had problems in supplying devices to DHL's Hong Kong depot in time for the first containers so they were sent with EDC devices only. In retrospect it was apparent that the CIMC device, as a rapidly developed prototype, was under test/trial as much as the interface between Integrity and SmartCM.

11.4.3 SICIS Conclusions

The key objective of the trial, to receive and process data from SmartCM was achieved as demonstrated by the quantity of the messages received from SmartCM. However the performance of the CSDs meant that the quality of the data still leaves room for improvement.

12 Consensus Building Activities

The INTEGRITY Advisory Board was a significant platform for active project communication and consensus management and consisted of delegates from a number of selected stakeholders which were considered relevant for the project. This group accompanied the project during its total lifetime. The Advisory Board was partly operated jointly by INTEGRITY and the project SmartCM.

Main purposes were to discuss and validate the INTEGRITY approach with a broader audience thus disseminating the project results receiving feedback. The Advisory Board was the heart of the consensus building exercise between the main target groups (authorities, cargo owners/shipper, transport operators) which was crucial for the successful implementation of the INTEGRITY concept for reaching its objectives and assured the wide distribution and dissemination of the project results. It had a crucial role to play in goal and target setting, proposing actions and providing opinion and feedback on strategies, activities and results generated through the platform operations.

The (Joint) Advisory Board consisted of:

- Representatives from additional Customs Authorities not directly involved in the project
- Partners from cooperating projects, e.g. the SSTL project
- Representatives from relevant associations
- Partners from different units of the European Commission
- Stakeholders from industries not directly covered in the project such as shipping companies and inland transport operators

13 Conclusion

The strong growth in container transport, bottlenecks in hinterland connections, complex logistics chains consisting of many actors, information gaps as well as new security regulations are challenges to be managed by industry and administration. The main factors in today's international intermodal container transport, logistics and security, are aiming at different objectives and sometimes lead to contradictory strategies.

INTEGRITY (www.integrity-supplychain.eu), co-funded by the European Commission, DG Research and coordinated by the Institute of Shipping Economics and Logistics (ISL), Bremen/Bremerhaven, Germany, has developed a methodology and an IT system serving both issues satisfying industry and authorities at the same time by creating supply chain visibility, thus optimizing the reliability and predictability of global door-to-door container transports.

From September 2009 until May 2011, the open IT platform SICIS (Shared Intermodal Container Information System) tracked more than 5400 containers along the entire logistics chain on several tradelanes from China to Europe by consolidating all relevant data and events which were generated during the transport. No other research project has handled such a large number of containers, underlining the potential of this innovative system.

SICIS is an open IT platform and offers various functions. As an example, interfaces to terminal operating systems were developed in order to feed terminal messages into the system. Another important feature is linking the container monitoring data with AIS vessel tracking information provided by satellites. A further essential SICIS feature especially for Customs is the possibility to upload consignment data, which can be used by Customs for further optimise risk assessment processes. The business evaluation performed within the project concluded with a positive feedback on the SICIS system. Most of the users were aware of the potential benefits of implementing and using the SICIS system.

SICIS can easily be adopted to any tradelane worldwide. Due to its sophisticated interfacing possibilities, there are practically no limitations in data exchange with other systems. Amongst others, interfaces to platforms like the EU projects SmartCM dealing with similar aspects of container visibility and CHINOS addressing the issue of RFID in container logistics were developed. Furthermore, data exchange with cooperation partners like DP World was established, which is the second of the worldwide leading terminal operators implementing data exchange with SICIS in addition to project partner Hutchison.

Major users of the approach are the commercial participants in the chain (3PLs, cargo owners, exporters, transport and port operators) and authorities (mainly Customs) creating a win-win situation for both of these groups. Due to the active involvement of Customs services along the intended demonstration chains as well as the close link to the EU/China Customs Project, the ease of administration together with supporting measures and incentives, e.g. the green lane for supervised secure transports, is covered as well.

14 Acknowledgements

The authors acknowledge the substantial and fruitful cooperation within the INTEGRITY Consortium and the fruitful discussions and feedback by the (Joint) Advisory Board, which both significantly facilitated the excellent achievements of the project.

The INTEGRITY Project was co-funded by the European Commission in its Seventh Framework Programme.

References

- A.T. Kearney (2005), Smart boxes - RFID Can Improve Efficiency, Visibility and Security in the Global Supply Chain, Chicago 2005.
- Aberdeen Group (2006), The Supply Chain Visibility Roadmap – Moving from Vision to True Business Value, Boston November 2006.
- Anderson, J. C., Narus, J. A., & van Rossum, W. (2006). Customer value propositions in business markets. *Harvard Business Review*, 84(3), 90-99.
- Astrata Group. (2009). TNT awards astrata container tracking system contract for its asia road network. Retrieved 07/21, 2009, from <http://www.astratagroup.com/index.php?action=news&newsID=192>.
- Beamon, B. M. (1998). Supply chain design and analysis: Models and methods. *International Journal of Production Economics*, 55(3), 281-294.
- Beamon, B. M. (1999). Measuring supply chain performance. *International Journal of Operations & Production Management* 19 (3-4): 275-292.
- Bititci, U. S., Martinez, V., Albores, P., & Parung, J. (2004). Creating and managing value in collaborative networks. *International Journal of Physical Distribution & Logistics Management*, 34, 251.
- Bouchard, T. J. J. (1976). Field research methods in industrial and organizational psychology. Chicago, Illinois: Rand McNally.
- Brewer, Peter C., Thomas W. Speh (2000), "Using the Balance scorecard to measure supply chain performance." *Journal of Business Logistics* (2) 1.
- Bullington, R. (2004). Presentation motorola inc., eyefortransport conference. Washington D.C., USA.
- Chow, H. K. H., Choy, K. L., Lee, W. B., & Chan, F. T. C. (2007). Integration of web-based and RFID technology in visualizing logistics operations - a case study. *Supply Chain Management*, 12(3), 221-234.
- Christopher, M., H.L. Lee (2004). "Mitigating supply chain risks through improved confidence." *Int. J. Physical Distribution & Logistics Management* 34 (5): 388-396.
- CommerceGuard AB. (2008a), CommerceGuard™ container security device (CSD).
- CommerceGuard AB. (2008b), CommerceGuard: Protecting and tracking global trade.
- Cook, T. D., & Campbell, D. T. (1979). Quasi-experimentation: Design and analysis issues for field setting. Chicago, Illinois: Rand McNally.
- Denning, P. J. (1997). New social contract for research. *Communications of the ACM*, 40(2), 132.
- Directive 2001/18/EC of the European Parliament and of the Council on the Deliberate Release into the Environment of Genetically Modified Organisms, (2001).
- Friedlos, D. (2009). Taiwan customs officials adopt RFID-enabled container seals., October 8.

GS1 Hong Kong. (2009). ezTrack leaflet.

GTT. (2008). Leaflet on tracking devices.

Hedman, J. J., & Kalling, T. (2003). The business model concept: Theoretical underpinnings and empirical illustrations. *European Journal of Information Systems*, 12(1), 49-59.

Hevner, A. R., March, S. T., Park, J., & Ram, S. (2004). Design science in information systems research. *MIS Quarterly*, 28(1), 75-105.

INTEGRITY (2008a). INTEGRITY project kicked-off. Heading towards a win-win situation between industry and customs for global container transport. Retrieved September 28th, 2009, from <http://www.integrity-supplychain.eu/>

INTEGRITY (2008b). Intermodal global door-to-door container supply chain visibility. Retrieved September 28th, 2009, from <http://www.integrity-supplychain.eu/>

Integrity (2009). SICIS – user acceptance test and training are accomplished. Retrieved October 7th, 2009, from <http://www.integrity-supplychain.eu/index.php?module=News&func=display&sid=14>

International Chamber of Commerce (2000). Incoterms 2000 No. 560.

International Organization for Standardization (1994). ISO 8402:1994

Introna, L. D. (1991). The impact of information technology on logistics. *International Journal of Physical Distribution & Logistics Management*, 21(5), 32-37.

Kambil, A., Ginsberg, A., & Bloch, M. (1997). Rethinking value propositions. NYU Center for Research on Information Systems.

Kaplan, R.S., S.R. Anderson (2007). The innovation of time-driven activity-based costing. *Journal of cost management* 21 (2): 5-15.

Kaplan, R.S., Norton, D.P. (1992). The balanced scorecard-measures that drive performance. *Harvard Business Review* 70 (1):71-79.

Kleindorfer, P. R., & Saad, G. H. (2005). Managing disruption risks in supply chains. *Production and Operations Management*, 14(1), 53-68.

Lai, K. H., E. W. T. Ngai, et al. (2002). Measures for evaluating supply chain performance in transport logistics. *Transportation Research Part E-Logistics and Transportation Review* 38 (6): 439-456.

Langley, C. J. J. (1986). Information-based decision making in logistics management. *International Journal of Physical Distribution & Materials Management*, 15(7), 41-55.

Lee, H. L., V. Padmanabhan, et al. (1997). Information distortion in a supply chain: The bullwhip effect. *Management Science* 43 (4): 546-558.

Lee, H.L., Ö. Özer (2007). Unlocking the Value of RFID. *Production and Operations Management* 16(1): 40-64.

Lee, H. L., & Whang, S. (2000). Information sharing in a supply chain. *International Journal of Manufacturing Technology and Management*, 1(1), 79.

- Lee, H.L., S. Whang (2005). Higher supply chain security with lower cost: Lessons from total quality management. *Int. J. Production Economics* 96: 289-300.
- Lee, H. L., & Wolfe, M. (2003). Supply chain security without tears. *Supply Chain Management Review*, 7(1), 12-21.
- Linder, J., & Cantrell, S. (2000). Changing business models: Surveying the landscape. Accenture Institute for Strategic Change.
- Magretta, J. (2002). Why business models matter. *Harvard Business Review*, 80(5), 86.
- Martinez, V., & Bititci, U. S. (2006). Aligning value propositions in supply chains. *International Journal of Value Chain Management*, 1(1), 6.
- Meijer, M. (2007). PROTECT D5.2 – information system architecture for supply chain security in container transport. Master Deliverable.
- Moonen, H., & Koolen, P. (2009). EURIDICE: Business models for logica.
- Neely, A., M. Gregory, et al. (1995). Performance measurement system design – A literature review and research agenda. *International Journal of Operations & Production Management* 15 (4): 80-116.
- Nunes, P., & Johnson, B. (2002). Stimulating consumer demand through meaningful. Accenture Institute for Strategic Change.
- Orlikowski, W. J., & Iacono, C. S. (2001). Research commentary: Desperately seeking the "IT" in IT research-A call to theorizing the IT artifact. *Information Systems Research*, 12(2), 121.
- Osterwalder, A. (2004). THE BUSINESS MODEL ONTOLOGY. l'Université de Lausanne, 2004.
- Osterwalder, A. (2005). What is a business model? Retrieved 07/14, 2009, from <http://business-model-design.blogspot.com/2005/11/what-is-business-model.html>
- Osterwalder, A. (2009a). Emmerce eDay - EyeOpener: 7 minutes on business models as a tool for success.
- Osterwalder, A. (2009b). How to systematically build business models beyond profit.
- Osterwalder, A., & Pigneur, Y. (2003). An ontology for e-business models. Value creation from E-business models (Currie, W.L. ed., pp. 65) Butterworth-Heinemann.
- Osterwalder, A., & Pigneur, Y. (2009). Business model generation.
- Paganelli, P., Charalampos, V., Cornelisse, E., Damenta, A., Forcolin, M., & Jermol, M. (2009). The EURIDICE project white paper.
- Peffer, K., Tuunanen, T., Rothenberger, M. A., & Chatterjee, S. (2007). A design science research methodology for information systems research. *Journal of Management Information Systems*, 24(3), 45-77.
- Peleg-Gillai, B. ; Bhat, G. ; Sept, L. (2006). Innovators in Supply Chain Security: Better Security Drives Business Value, Stanford 2006

- Popal, N. (2008). Information needs, requirements and recommendations for supply chain security. PROTECT Work Package 5.1.
- PROTECT (2005). Supply chain security: PROTECT survey 2005 - wat verwacht logistiek nederland?
- Rice, J. B., & Spayd, P. W. (2005). Investing in supply chain security: Collateral benefits. Special report series IBM center of the business of government.
- Ruggles, R. (2002). Connectivity reinvents the rules of innovation. Perspectives on Business Innovation, 8, 7-15.
- Sekarau, U. (2003). Research methods for business. John Wiley & Sons, 2003.
- Sheffi, Y. (2001). Supply chain management under the threat of international terrorism. The International Journal of Logistics Management, 12(2), 1.
- Smart & Secure Tradelanes (2003). Phase One Review – Network Visibility: Leveraging Security and Efficiency in Today’s Global Supply Chains, November 2003.
- Straub, D., Boudreau, M., & Gefen, D. (2004). Validation guidelines for is positivist research. Communications of AIS, 2004(13), 380-427.
- Strong, D. M. (1997). Data quality in context. Communications of the ACM, 40(5), 103.
- Sycada. (2008), Sycada m!trace guardian.
- Timmers, P. P. (1998). Business models for electronic markets. Electronic Markets, 8(2), 3-8.
- Tuomi, I. (1999). Data is more than knowledge: Implications of the reversed knowledge hierarchy for knowledge management and organizational memory. Journal of Management Information Systems, 16(3), 103-117.
- United Nations. (2009). ‘ROTTERDAM RULES’ IN MARITIME TRANSPORT OF GOODS. Rotterdam, 2009.
- Veenstra, A., Hintsa, J., & Zomer, G. (2008). Global container supply chain compendium. INTEGRITY Deliverable D1.1, retrieved on <http://www.integrity-supplychain.eu>
- Wilson, T. P. (1998). Food safety and traceability in the agricultural supply chain: Using the internet to deliver traceability. Supply Chain Management, 3(3), 127.
- Yeon. (2009). YEON TAG YTE-100 brochure.
- Zhou, H., & Benton Jr, W. C. (2007). Supply chain practice and information sharing. Journal of Operations Management, 25(6), 1348-1365.